

NASA/TM-1999-209104

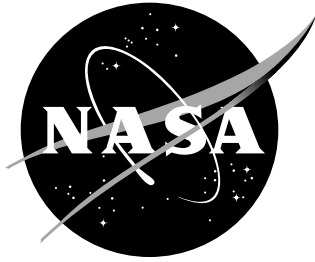

Computational Test Cases for a Clipped Delta Wing With Pitching and Trailing-Edge Control Surface Oscillations

*Robert M. Bennett and Charlotte E. Walker
Langley Research Center, Hampton, Virginia*

March 1999

The NASA STI Program Office ... in Profile

Since its founding, NASA has been dedicated to the advancement of aeronautics and space science. The NASA Scientific and Technical Information (STI) Program Office plays a key part in helping NASA maintain this important role.

The NASA STI Program Office is operated by Langley Research Center, the lead center for NASA's scientific and technical information. The NASA STI Program Office provides access to the NASA STI Database, the largest collection of aeronautical and space science STI in the world. The Program Office is also NASA's institutional mechanism for disseminating the results of its research and development activities. These results are published by NASA in the NASA STI Report Series, which includes the following report types:

- **TECHNICAL PUBLICATION.** Reports of completed research or a major significant phase of research that present the results of NASA programs and include extensive data or theoretical analysis. Includes compilations of significant scientific and technical data and information deemed to be of continuing reference value. NASA counterpart of peer-reviewed formal professional papers, but having less stringent limitations on manuscript length and extent of graphic presentations.
- **TECHNICAL MEMORANDUM.** Scientific and technical findings that are preliminary or of specialized interest, e.g., quick release reports, working papers, and bibliographies that contain minimal annotation. Does not contain extensive analysis.
- **CONTRACTOR REPORT.** Scientific and technical findings by NASA-sponsored contractors and grantees.

- **CONFERENCE PUBLICATION.** Collected papers from scientific and technical conferences, symposia, seminars, or other meetings sponsored or co-sponsored by NASA.
- **SPECIAL PUBLICATION.** Scientific, technical, or historical information from NASA programs, projects, and missions, often concerned with subjects having substantial public interest.
- **TECHNICAL TRANSLATION.** English-language translations of foreign scientific and technical material pertinent to NASA's mission.

Specialized services that complement the STI Program Office's diverse offerings include creating custom thesauri, building customized databases, organizing and publishing research results ... even providing videos.

For more information about the NASA STI Program Office, see the following:

- Access the NASA STI Program Home Page at <http://www.sti.nasa.gov>
- E-mail your question via the Internet to help@sti.nasa.gov
- Fax your question to the NASA STI Help Desk at (301) 621-0134
- Phone the NASA STI Help Desk at (301) 621-0390
- Write to:
NASA STI Help Desk
NASA Center for AeroSpace Information
7121 Standard Drive
Hanover, MD 21076-1320

NASA/TM-1999-209104

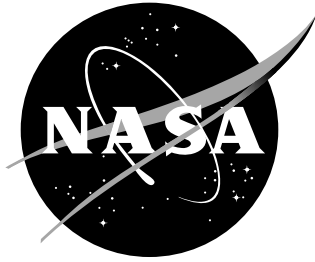

Computational Test Cases for a Clipped Delta Wing With Pitching and Trailing-Edge Control Surface Oscillations

*Robert M. Bennett and Charlotte E. Walker
Langley Research Center, Hampton, Virginia*

National Aeronautics and
Space Administration

Langley Research Center
Hampton, Virginia 23681-2199

March 1999

The use of trademarks or names of manufacturers in the report is for accurate reporting and does not constitute an official endorsement, either expressed or implied, of such products or manufacturers by the National Aeronautics and Space Administration.

Available from:

NASA Center for AeroSpace Information (CASI)
7121 Standard Drive
Hanover, MD 21076-1320
(301) 621-0390

National Technical Information Service (NTIS)
5285 Port Royal Road
Springfield, VA 22161-2171
(703) 605-6000

Abstract

Computational test cases have been selected from the data set for a clipped delta wing with a six-percent-thick circular-arc airfoil section that was tested in the NASA Langley Transonic Dynamics Tunnel. The test cases include parametric variation of static angle of attack, pitching oscillation frequency, trailing-edge control surface oscillation frequency, and Mach numbers from subsonic to low supersonic values. Tables and plots of the measured pressures are presented for each case. This report provides an early release of test cases that have been proposed for a document that supplements the cases presented in AGARD Report 702.

Nomenclature

c	local chord, ft (m)
c_r	wing root chord, ft (m)
C_p	pressure coefficient, $(p-p_\infty)/q_\infty$
f	frequency, Hz
H_o	freestream total pressure, psf (kPa)
k	reduced frequency based on root semichord, $\omega c_r/(2V_\infty)$
p	pressure, psf (kPa)
p_∞	freestream static pressure, psf (kPa)
q_∞	dynamic pressure, psf (kPa)
R_N	Reynolds number based on average chord
s	semispan, ft (m)
t/c	airfoil thickness to chord ratio
T_o	total or stagnation temperature, °R (°C)
V_∞	freestream velocity, ft/sec (m/sec)
x/c	streamwise fraction of local chord
y	spanwise coordinate normal to freestream
α_o	mean angle of attack, degrees
θ	amplitude of pitch oscillations, degrees or radians
δ	amplitude of control surface oscillations, degrees or radians
δ_o	mean control surface deflection, degrees or radians

η	fraction of span, y/s
γ	ratio of specific heats for test gas
ω	frequency, radians/second

Introduction

Steady and unsteady measured pressures for a clipped delta wing (referred to by CDW) undergoing pitching oscillations and trailing-edge control surface oscillations have been presented in references 1 and 2. From the several hundred compiled data points, 22 static cases, 12 pitching-oscillation cases, and 12 control-surface-oscillation cases have been proposed for computational test cases to illustrate the trends with Mach number, reduced frequency, and angle of attack.

The planform for this wing was derived by simplifying the planform of a proposed design for a supersonic transport which is described (ref. 3) as the Boeing 2707-300. The strake was deleted, the resulting planform was approximated by a trapezoid with an unswept trailing edge, and the twist and camber were removed. In order to facilitate pressure instrumentation, the thickness was increased to 6 percent from the typical 2.5 to 3 percent for the supersonic transport. The airfoil is thus a symmetrical circular arc section with $t/c = 0.06$. A wing of similar planform but with a thinner airfoil of $t/c = 0.03$ was used in the flutter investigations of references 4 and 5, and a buffeting and stall flutter investigation documented in an internal report (NASA LWP-872, May 1970). Flutter results are also reported both for the 3% thick simplified wing and for a more complex SST model in reference 6.

One of the consequences of the increased thickness of the clipped delta wing is that transonic effects are enhanced for Mach numbers near one. They are significantly stronger than would be the case for the thinner wing. Also, with the combination of high leading edge sweep of 50.5° and the sharp leading edge, a leading edge vortex forms on the wing at relatively low angles of attack, on the order of three degrees. The Appendix of reference 1 discusses some of the vortex flow effects. In addition, a shock develops over the aft portion of the wing at transonic speeds such that at some angles of attack, there is both a leading edge vortex and a shock wave on the wing. Such cases are a computational challenge. Some previous applications of this data set have been for the evaluation of an aerodynamic panel method (ref. 7) and for evaluation of a Navier-Stokes capability (ref. 8-10). Linear theory and panel method results are also presented in reference 1, which demonstrated the need for inclusion of transonic effects. Flutter calculations for the related wing with $t/c=0.03$ are given in references 4 and 11.

In this report several test cases are selected to illustrate trends for a variety of different conditions with emphasis on transonic flow effects. An overview of the model and tests are given, and the standard formulary for these data is listed. All of the data are presented in both tabular and graphical form. Only the static pressures and the 1st harmonic real and imaginary parts of the pressures are available. All of the data for the test are included in a microfiche document in the original report (ref. 1) and are available in electronic file form. The test cases are also available as separate electronic files.

This report provides an early release of test cases that have been proposed for a document that supplements the cases presented in AGARD Report 702 (ref. 12-13) and is being generated under the NATO Research and Technology Organization (RTO) Applied Vehicle Technology (AVT) Working Group - 003. The overall description of the data set is given in the body of this report by a formulary similar to that used in AGARD Report 702.

Model and Tests

The clipped delta wing model was tested in the NASA Langley Transonic Dynamics Tunnel (TDT). The tunnel has a slotted test section 16-feet (4.064 m) square with cropped corners. At the time of these tests, it could be operated with air or a heavy gas, R-12, as a test medium at pressures from very low to near atmospheric values. Currently the TDT can be operated with air or R-134a as a test medium. An early description of this facility is given in an internal report (NASA LWP-799, Sep. 1969) and the early data system is described in reference 14. More recent descriptions of the facility are given in references 15 and 16, and of the recent data system are given in references 17 and 18. Based on cone transition results (ref. 19-20), the turbulence level for this tunnel is in the average large transonic tunnel category. Some low speed measurements in air have also been presented in reference 21.

The model is shown installed in the TDT in figure 1, the basic structure is illustrated in figure 2, and the overall planform and instrumentation layout is given in figure 3. The model was mounted on a splitter plate offset from the wall. An end plate was fixed to the wing root and moved with the model. To prevent leakage between the end plate and the splitter plate, the region where the splitter plate overlapped the end plate was sealed. The leading edge control surface shown in the figure was fixed and the side edges smoothly faired into the wing. The hinge line at 15 per cent chord was sealed but not smoothed. The trailing-edge control surface (figs. 1-3) had a hinge line at 80 per cent chord which was sealed but not smoothed. The side edges were not sealed. The model was oscillated in pitch as a mass-spring system with a large spring mechanism located behind the tunnel wall that was driven hydraulically. It could be set at various mean angles, and the amplitude and frequency of oscillation varied. The trailing edge control surface was oscillated with a miniature hydraulic actuator located within the wing at the control surface and attached directly to the shaft along the control hinge line.

The wing was constructed with stainless steel ribs and spars and Kevlar-epoxy skins. Although no stiffness measurements were made, it was considered very stiff. Based on accelerometer measurements, the wind-off node lines showed only a modest variation with frequency in the range of interest (fig. 4). The control surface was constructed with ribs, spars, and skin of graphite-epoxy for low weight and high stiffness.

The instrumentation was mostly on the upper surface (shown in fig. 3) with a few transducers on the lower surface to establish symmetry and zero angle of attack. There are 5 chordwise locations for the transducers, with chord C consisting of a few transducers near the edges of the control surfaces. Static and dynamic measurements were made separately, with a static orifice adjacent to each dynamic transducer. The locations of the static orifices are given in table 1, and locations of the orifices for the dynamic transducers are given in table 2. The static pressure tubing was also connected to the reference side of the corresponding dynamic orifices through 35 feet (10.7 m) of .020 inch (.51 mm) diameter tubing to damp out unsteady effects on the reference pressure.

Although ordinates were measured for this wing, it was concluded that the basic definition of a $t/c = 0.06$ circular arc was adequate to describe the geometry of the wing and the measured ordinates were not published. It was noted (ref. 1) that the control surface had two degrees of twist, which was averaged by setting the inboard portion low and the outboard portion high.

As can be seen in figure 1, the model was tested with the sidewall slots of the test section open. Some recent unpublished results for a model of about twice the root chord of this model and mounted directly to the wind tunnel wall have shown an order of ten percent influence of closing the slots on static lift curve slope (similar to those measured in ref. 22). Significantly less influence would be anticipated for this smaller model which was mounted on a splitter plate.

Test Cases

The static test cases chosen for the clipped delta wing (CDW) are given in table 3, and the dynamic test cases are presented in tables 4 and 5. The code, or point index, for the cases are designated with a two-digit value of the test Mach number, followed by an S for static or D for dynamic, and followed by a sequence number for each Mach number (ref. 1). The test case number is related to the enumeration given in the RTO chapter. The pitch cases are chosen to indicate trends with Mach number at zero angle of attack, trends with Mach number at small values of angle of attack, and trends with angle of attack at one low and one transonic Mach number (including some cases with leading edge vortex flows). The trailing-edge control cases also illustrate trends with Mach number and the static deflection amplitude of the trailing-edge control surface. The dynamic cases are chosen to evaluate unsteady effects at these static conditions. One feature of this data set is a relatively high Reynolds number for the test, of the order of 10×10^6 based on the average chord.

All the data for the static test cases are tabulated and shown in the composite plots in figure 5. The data for the dynamic cases are also tabulated and shown in the plots of figure 6 in terms of in-phase and out-of-phase parts (real and imaginary) of the pressure normalized by the amplitude of the dynamic motion, either pitch or control-surface oscillation (in radians). The phase reference is the input dynamic motion. More figures than are significant are retained in the tables to accurately reproduce the phase angles of the original tabulations. For each of these cases, the data points are connected by straight lines for visual continuity only and the lines are not intended to be considered a fairing of the data.

Note that all of the tests for CDW were conducted with the heavy gas, R-12, as the test medium. The ratio of specific heats, γ , is calculated to be 1.132 to 1.135 for the conditions of the test assuming 0.99 for the fraction of heavy gas in the heavy gas-air mixture. A value of 1.132 is suggested for use in computational comparisons. The corresponding value of Prandtl number is calculated to range from 0.77 to 0.78 for the conditions of this test.

Formulary for the Clipped Delta Wing Data Set

1. General Description of model

1.1 Designation	Clipped Delta Wing (CDW)
1.2 Type	Semispan wing
1.3 Derivation	Simplified version of early SST with thicker airfoil (see Introduction)
1.4 Additional remarks	Shown mounted in tunnel in figure 1
1.5 References	References 1 and 2 are the original source

2. Model Geometry

2.1 Planform	Trapezoidal
2.2 Aspect ratio	1.242 for panel
2.3 Leading edge sweep	50.4 deg.
2.4 Trailing edge sweep	Unswep
2.5 Taper ratio	0.1423
2.6 Twist	None

2.7 Wing centerline chord	63.55 inches (1614 mm)
2.8 Semi-span of model	45.08 inches (1145 mm)
2.9 Area of planform	1635.88 sq. in. (1.0554 sq. m)
2.10 Location of reference sections and definition of profiles	Reduced frequency based on root semichord, 31.775 inches (807.1 mm)
2.11 Lofting procedure between reference sections	Constant per cent thickness airfoil
2.12 Form of wing-body junction	No fairing, sealed at splitter plate
2.13 Form of wing tip	Sharply cut off
2.14 Control surface details	Trailing edge control, 80% chord between 56.6% span and 82.9% span. Hinge line sealed, but side edges open. About two degrees twist in control surface, with inboard trailing edge low and outboard high
2.15 Additional remarks	See figure 3 for overview
2.16 References	References 1 and 2

3. Wind Tunnel

3.1 Designation	NASA LaRC Transonic Dynamics Tunnel (TDT)
3.2 Type of tunnel	Continuous flow, single return
3.3 Test section dimensions	16 ft x 16 ft (4.064 x 4.064 m)
3.4 Type of roof and floor	Three slots each
3.5 Type of side walls	Two sidewall slots
3.6 Ventilation geometry	Constant width slots in test region
3.7 Thickness of side wall boundary layer	Some documentation in NASA LWP-799. Model tested with splitter plate
3.8 Thickness of boundary layers at roof and floor	Not documented
3.9 Method of measuring velocity	Calculated from static pressures measured in plenum and total pressure measured upstream of entrance nozzle of test section
3.10 Flow angularity	Not documented, considered small
3.11 Uniformity of velocity over test section	Not documented, considered nearly uniform
3.12 Sources and levels of noise or turbulence in empty tunnel	Generally unknown. Some low speed measurements are presented in reference 21. Cone transition measurements are presented in references 19 and 20
3.13 Tunnel resonances	Unknown
3.14 Additional remarks	Tests performed in heavy gas, R-12. Ratio of specific heats, γ , is 1.132-1.135. For computations, 1.132 is recommended. For the conditions of this test, the Prandtl number is calculated to be 0.77-0.78
3.15 References on tunnel	Reference 15, 16, and NASA LWP-799

4. Model Motion

4.1 General description	Pitching about 65.22% of root chord for wing. Oscillation about the control surface hinge line
4.2 Reference coordinate and definition of motion	Pitch about axis normal to freestream. Control surface oscillation about 80% chord line of wing
4.3 Range of amplitude	Pitch amplitude of 0.25 and 0.50 degrees. Control surface oscillation of 2, 4, and 6 degrees
4.4 Range of frequency	4, 8, and 16 Hz for wing pitch, and 8, 16, and 22 Hz for control surface oscillations
4.5 Method of applying motion	Pitch oscillations generated as spring-mass system driven by hydraulic actuator. Control surface oscillations were driven by a miniature hydraulic actuator at the control surface
4.6 Timewise purity of motion	Not documented
4.7 Natural frequencies and normal modes of model and support system	First natural frequency was 28 Hz
4.8 Actual mode of applied motion	Not documented except for node lines for wind-off conditions. See figure 4
4.9 Additional remarks	None

5. Test Conditions

5.1 Model planform area/tunnel area	.05
5.2 Model span/tunnel height	.23
5.3 Blockage	Model less than 0.3%
5.4 Position of model in tunnel	Mounted from splitter plate on wall and in the center of the tunnel
5.5 Range of Mach number	0.40 to 1.12
5.6 Range of tunnel total pressure	530 to 1005 psf (25.4 to 48.1 kPa)
5.7 Range of tunnel total temperature	512 to 576 degrees Rankine (23 to 47° C)
5.8 Range of model steady or mean incidence	0 to 5.5 degrees
5.9 Definition of model incidence	From chord line of symmetric airfoil
5.10 Position of transition, if free	Transition strip used
5.11 Position and type of trip, if transition fixed	Grit strip 0.1 inch wide (2.5 mm) at 8 % chord on upper and lower surfaces. Number 70 grit from root to midspan and number 90 from midspan to tip (number is approximately grains per inch (per 25.4 mm))
5.12 Flow instabilities during tests	None defined
5.13 Changes to mean shape of model due to steady aerodynamic load	Not measured but considered very stiff

5.14 Additional remarks	Tests performed in heavy gas, R-12. Ratio of specific heats, γ , is 1.132-1.135. For computations, 1.132 is recommended. For the conditions of this test, the Prandtl number is calculated to be 0.77-0.78
5.15 References describing tests	References 1 and 2

6. Measurements and Observations

6.1 Steady pressures for the mean conditions	yes
6.2 Steady pressures for small changes from the mean conditions	yes
6.3 Quasi-steady pressures	no
6.4 Unsteady pressures	yes
6.5 Steady section forces for the mean conditions by integration of pressures	no
6.6 Steady section forces for small changes from the mean conditions by integration	no
6.7 Quasi-steady section forces by integration	no
6.8 Unsteady section forces by integration	no
6.9 Measurement of actual motion at points of model	no
6.10 Observation or measurement of boundary layer properties	no
6.11 Visualisation of surface flow	no
6.12 Visualisation of shock wave movements	no
6.13 Additional remarks	no

7. Instrumentation

7.1 Steady pressure	
7.1.1 Position of orifices spanwise and chordwise	6 to 16 chordwise locations at 5 spanwise stations. See figure 3 and table 1
7.1.2 Type of measuring system	Scani-valve
7.2 Unsteady pressure	
7.2.1 Position of orifices spanwise and chordwise	6 to 16 chordwise locations at 5 spanwise stations. See figure 3 and table 2. Slightly different locations than steady
7.2.2 Diameter of orifices	.056 inches (1.4 mm)
7.2.3 Type of measuring system	In situ pressure gages

7.2.4	Type of transducers	Kulite
7.2.5	Principle and accuracy of calibration	Calibrated dynamically using method of reference 23. Also statically calibrated through reference tubes
7.3	Model motion	
7.3.1	Method of measuring motion reference coordinate	Undocumented
7.3.2	Method of determining spatial mode of motion	Wind-off verification with accelerometers
7.3.3	Accuracy of measured motion	Undocumented
7.4	Processing of unsteady measurements	
7.4.1	Method of acquiring and processing measurements	Analog signals digitized at about 940 samples/sec for 10-30 seconds depending on frequency
7.4.2	Type of analysis	Fourier analysis
7.4.3	Unsteady pressure quantities obtained and accuracies achieved	Amplitude and phase of each pressure signal. Accuracy not specified
7.4.4	Method of integration to obtain forces	None
7.5	Additional remarks	None
7.6	References on techniques	Data system overview for test given in reference 14

8. Data Presentation

8.1	Test cases for which data could be made available	All data are available
8.2	Test cases for which data are included in this document	Sample data tabulated and plotted for each type of test case. Complete plotting and tabulation of each case
8.3	Steady pressures	Available for each test case
8.4	Quasi-steady or steady perturbation pressures	Steady pressures measured for several angles of attack
8.5	Unsteady pressures	Primary data. First harmonic only. No time histories saved. C_p magnitude and phase of reference 1 converted to real and imaginary parts and normalized by amplitude of oscillation (in radians) for this report.
8.6	Steady forces or moments	Some static hinge moments for control surface plotted in reference 1. No other force measurements
8.7	Quasi-steady or unsteady perturbation forces	None
8.8	Unsteady forces and moments	None
8.9	Other forms in which data could be made available	None

8.10 Reference giving other representations of data

References 1-2 and 7-10

9. Comments on Data

9.1 Accuracy

9.1.1 Mach number

Not documented

9.1.2 Steady incidence

Zero set by pressure difference. Accuracy of other values unknown

9.1.3 Reduced frequency

Should be accurate

9.1.4 Steady pressure coefficients

Not documented

9.1.5 Steady pressure derivatives

None

9.1.6 Unsteady pressure coefficients

Not documented, but each gage individually calibrated dynamically and monitored statically

9.2 Sensitivity to small changes of parameter

None indicated. Amplitudes of oscillation varied in test

9.3 Non-linearities

Plotted hinge moments (ref. 2) show some nonlinearity. Many flow conditions involve shock waves; some with leading edge vortex flows

9.4 Influence of tunnel total pressure

Not evaluated. Most of the test at constant dynamic pressure

9.5 Effects on data of uncertainty, or variation, in mode of model motion

Unknown; not expected to be appreciable. Wind-off measurements shown in figure 4

9.6 Wall interference corrections

None applied

9.7 Other relevant tests on same model

None

9.8 Relevant tests on other models of nominally the same shapes

Flutter tests on similar planform but thinner airfoil presented in references 4-6, and NASA LWP-872

9.9 Any remarks relevant to comparison between experiment and theory

Leading edge vortex forms near 3 degrees angle of attack. Some cases have both vortex flow and shock waves

9.10 Additional remarks

Wing mostly instrumented on one side. Upper and lower surface data assembled from varying angle of attack

9.11 References on discussion of data

References 1-2 and 7-10

10. Personal Contact for Further Information

Head, Aeroelasticity Branch
Mail Stop 340
NASA Langley Research Center
Hampton, VA 23681-2199 USA

Phone: +1-(757)-864-2820
FAX: +1-(757)-864-8678

Concluding Remarks

Steady and unsteady measured pressures for a clipped delta wing undergoing pitching oscillations and trailing-edge control surface oscillations were reviewed. From the several hundred compiled data points, 22 static cases, 12 pitching-oscillation cases, and 12 control-surface-oscillation cases have been proposed for computational test cases to illustrate the trends with Mach number, reduced frequency, and angle of attack. An overview of the model and tests are given, and the standard formulary for these data is listed. All of the data are presented in both tabular and graphical form. This report provides an early release of test cases that have been proposed for a document that supplements the cases presented in AGARD Report 702 and is being generated under the NATO Research and Technology Organization (RTO) Applied Vehicle Technology (AVT) Working Group - 003.

NASA Langley Research Center
Hampton, VA 23681-2199
March 4, 1999

References

1. Hess, Robert W.; Cazier, F. W., Jr.; and Wynne, Eleanor C.: *Steady and Unsteady Transonic Pressure Measurements on a Clipped Delta Wing for Pitching and Control-Surface Oscillations*. NASA TP-2594, Oct. 1986.
2. Hess, R. W.; Cazier, F. W., Jr.; and Wynne, E. C.: *Static and Unsteady Pressure Measurements on a 50 degree Clipped Delta Wing at $M = 0.9$* . AIAA Paper 82-0686, 1982. Also available as NASA TM-83297, 1982.
3. Bhatia, Kumar G.; and Wertheimer, Jiri: *Aeroelastic Challenges for a High Speed Civil Transport*. AIAA Paper 93-1478, May 1993.
4. Sandford, Maynard C.; Abel, Irving; and Gray, David L.: *Development and Demonstration of a Flutter-Suppression System Using Active Controls*. NASA TR R-450, 1974.
5. Sandford, Maynard C.; Ruhlin, Charles L.; and Abel, Irving: *Transonic Flutter Study of a 50.5-Deg. Cropped-Delta Wing with Two Rearward-Mounted Nacelles*. NASA TN D-7544, 1974.
6. Ruhlin, Charles L.; Destuynder, Roger M.; and Gregory, Richard A.: *Some Wind Tunnel Wall Effects on Transonic Flutter*. Journal of Aircraft, vol. 12, no. 3, Mar. 1975, pp 162-167.
7. Yates, E. Carson, Jr.; Cunningham, Herbert J.; Desmarais, Robert N.; Silva, Walter A.; and Drobenko, Bohdan: *Subsonic Aerodynamic and Flutter Characteristics of Several Wings Calculated by the SOUSSA P1.1 Panel Method*. AIAA Paper 82-0727, May 1982.
8. Guruswamy, Guru P.; and Obayashi, Shigeru: *Transonic Aeroelastic Computations on Wings Using Navier-Stokes Equations*. Paper No. 22 in "Transonic Unsteady Aerodynamics and Aeroelasticity", AGARD-CP-507, Mar. 1992.
9. Obayashi, Shigeru; and Guruswamy, Guru P.: *Unsteady Shock-Vortex Interaction on a Flexible Delta Wing*. Journal of Aircraft, vol. 29, no. 5, Sept.-Oct. 1992, pp 790-798.
10. Obayashi, Shigeru; and Guruswamy, Guru P.: *Navier-Stokes Computations for Oscillating Control Surfaces*. Journal of Aircraft, vol. 31, no. 3, May-June 1994, pp. 631-636.

11. Bennett, Robert M.; Batina, John T.; and Cunningham, H. J.: *Wing-Flutter Calculations with the CAP-TSD Unsteady Transonic Small-Disturbance Program*. Journal of Aircraft, vol. 26, no. 9, Sep. 1989, pp. 876-882.
12. *Compendium of Unsteady Aerodynamic Measurements*. AGARD Report No. 702, Aug. 1982.
13. *Compendium of Unsteady Aerodynamic Measurements. Addendum No. 1*. AGARD Report No. 702, May 1985.
14. Cole, Patricia H.: *Wind Tunnel Real-Time Data Acquisition System*. NASA TM 80081, 1979.
15. Cole, Stanley, R.; and Rivera, Jose, A, Jr.: *The New Heavy Gas Testing Capability in the NASA Langley Transonic Dynamics Tunnel*. Paper No. 4 presented at the Royal Aeronautical Society Wind Tunnels and Wind Tunnel Test Techniques Forum, Churchill College, Cambridge, UK, Apr. 1997.
16. Corliss, James M.; and Cole, Stanley R.: *Heavy Gas Conversion of the NASA Langley Transonic Dynamics Tunnel*. AIAA Paper 98-2710, June 1998.
17. Wieseman, Carol D.; and Hoadley, Sherwood, T.: *Versatile Software Package for Near Real-Time Analysis of Experimental Data*. AIAA Paper 98-2722, June, 1998.
18. Bryant, C.; and Hoadley, S. T.: *Open Architecture Dynamic Data System at Langley's Transonic Dynamics Tunnel*. AIAA Paper 98-0343, Jan. 1998.
19. Dougherty, N. Sam, Jr.: *Influence of Wind Tunnel Noise on the Location of Boundary-Layer Transition on a Slender Cone at Mach Numbers from 0.2 to 5.5. Volume I. - Experimental Methods and Summary of Results. Volume II. - Tabulated and Plotted Data*. AEDC--TR-78-44, March 1980.
20. Dougherty, N. Sam, Jr.; and Fisher, D. F.: *Boundary-Layer Transition on a 10-Deg. Cone: Wind Tunnel/Flight Correlation*. AIAA Paper 80-0154, January 1980.
21. Sleeper, Robert K.; Keller, Donald F.; Perry, Boyd, III; and Sandford, Maynard C.: *Characteristics of Vertical and Lateral Tunnel Turbulence Measured in Air in the Langley Transonic Dynamics Tunnel*. NASA TM 107734, March 1993.
22. Lambourne, N.; Destuynder, R.; Kienappel, K.; and Roos, R.: *Comparative Measurements in Four European Wind Tunnels of the Unsteady Pressures on an Oscillating Model (The NORA Experiments)*. AGARD Report No. 673, Feb. 1980.
23. Bolt, Pamela C.; Hess, Robert W.; and Davis William T.: *Portable Dynamic Pressure Generator for Static and Dynamic Calibration of In-Situ Pressure Transducers*. NASA TM 85687, 1983.

Table 1. Orifice Locations for Steady Measurements

Chord A	Chord B	Chord C	Chord D	Chord E
y/s				
0.332	0.541	0.587	0.694	0.851
x/c				
0.0778	0.0687	0.0818	0.0675	0.2070
0.1264	0.1282	0.1318	0.1151	0.2559
0.2020	0.2529	0.2099	0.1980	0.3016
0.2523	0.3041	0.7875	0.2559	0.3537
0.3023	0.3531	0.8522	0.3041	0.4583
0.3519	0.4530	0.9017	0.3545	0.5562
0.4510	0.5036	0.9514	0.4537	0.6074
0.5523	0.5534		0.5025	0.6577
0.6025	0.6040		0.5527	0.7071
0.6515	0.6528		0.6038	0.7975
0.6991	0.7030		0.6538	
0.7813	0.7694		0.7025	
0.8505	0.8967		0.7754	
0.9001	0.9512		0.8553	
0.9596			0.9037	
			0.9526	

Table 2. Orifice Locations for Unsteady Measurements

Chord A	Chord B	Chord C	Chord D	Chord E
y/s				
0.337	0.546	0.590	0.698	0.856
x/c				
0.0731	0.0681	0.0767	0.0754	0.1955
0.1120	0.1237	0.1271	0.1237	0.2458
0.1974	0.2485	0.1993	0.1980	0.2915
0.2478	0.3004	0.7802	0.2502	0.3454
0.2987	0.3481	0.8514	0.3001	0.4519
0.3486	0.4487	0.9016	0.3476	0.5497
0.4477	0.4997	0.9511	0.4495	0.6025
0.5506	0.5500		0.4974	0.6545
0.6009	0.6014		0.5484	0.7049
0.6459	0.6494		0.6007	0.7808
0.6979	0.6995		0.6514	
0.7805	0.7747		0.7000	
0.8500	0.8964		0.7795	
0.8996			0.8547	
0.9495			0.9033	
			0.9522	

Table 3. Static Test Cases

Test Case No.	Point (Code ¹)	M	α_o deg.	δ_o deg.	Comments
9E1	.40-S-1	.399	.05	0.	vs M, $\alpha_o = 0^\circ$
9E2	.88-S-1	.883	.05	0.	
9E3	.90-S-1	.899	.05	0.	
9E4	.92-S-1	.921	.05	0.	
9E5	.94-S-1	.944	.05	0.	
9E6	.96-S-1	.965	.00	0.	
9E7	1.12-S-1	1.120	.00	0.	
9E8	.40-S-6	.400	1.03	0.	vs M, $\alpha_o = 1^\circ$
9E9	.90-S-5	.909	.99	0.	
9E10	.94-S-6	.943	.97	0.	
9E11	1.12-S-6	1.120	.99	0.	
9E12	.40-S-11	.404	3.04	0.	vs α_o @M
9E13	.40-S-15	.403	5.04	0.	
9E14	.90-S-19	.900	2.99	0.	
9E15	.90-S-38	.901	4.24	0.	
9E16	.40-S-3	.406	.05	4.	vs δ_o , $\alpha_o = 0$
9E17	.90-S-2	.898	.05	2.	
9E18	.90-S-3	.896	.05	4.	
9E19	.94-S-3	.944	.05	4.	
9E20	1.12-S-3	1.120	.00	4.	
9E21	.90-S-21	.901	2.99	4.	vs δ_o @ α_o
9E22	.90-S-24	.896	2.99	-4.	

¹ Reference 1

Table 4. Test Cases for Pitching Oscillations

Test Case No.	Point (Code ¹)	M	α_0 deg.	θ deg.	f Hz	k	Comments
9E23	.40-D-5	.403	.05	.47	4.00	.194	vs M
9E24	.88-D-5	.885	.05	.48	7.98	.173	
9E25	.90-D-5	.904	.00	.46	7.99	.167	
9E26	.92-D-5	.921	.05	.47	7.97	.166	
9E27	.94-D-5	.945	.05	.47	7.98	.162	
9E28	.96-D-4	.961	.04	.50	7.99	.158	
9E29	1.12-D-5	1.120	.00	.47	8.00	.136	
9E30	.90-D-2	.905	.00	.24	7.99	.168	Lower θ
9E31	.90-D-4	.904	.00	.50	4.01	.084	Lower k
9E32	.90-D-6	.909	.00	.46	16.01	.335	Higher k
9E33	.40-D-24	.403	5.02	.50	4.00	.189	Higher α_0
9E34	.90-D-29	.902	3.97	.46	7.99	.169	Higher α_0

¹ Reference 1

Table 5. Test Cases for Control Surface Oscillations

Test Case No.	Point (Code ¹)	M	α_o deg.	δ deg.	f Hz	k	Comments
9E35	.40-D-32	.405	.05	3.90	7.99	.376	vs M
9E36	.88-D-34	.878	.05	3.88	16.00	.350	
9E37	.90-D-35	.901	.05	4.00	16.00	.338	
9E38	.92-D-33	.923	.05	3.93	15.98	.337	
9E39	.94-D-34	.942	.05	3.96	15.98	.326	
9E40	.96-D-10	.960	.05	4.54	16.00	.315	
9E41	1.12-D-11	1.120	.00	4.37	16.01	.273	
9E42	.90-D-32	.898	.05	3.48	7.99	.170	Lower k
9E43	.92-D-36	.924	.05	3.89	22.00	.459	Higher k
9E44	.90-D-34	.898	.05	1.97	16.00	.339	Lower δ
9E45	.90-D-36	.899	.04	5.82	16.01	.340	Higher δ
9E46	.90-D-59	.901	2.99	4.39	16.01	.337	Higher α_o

¹ Reference 1

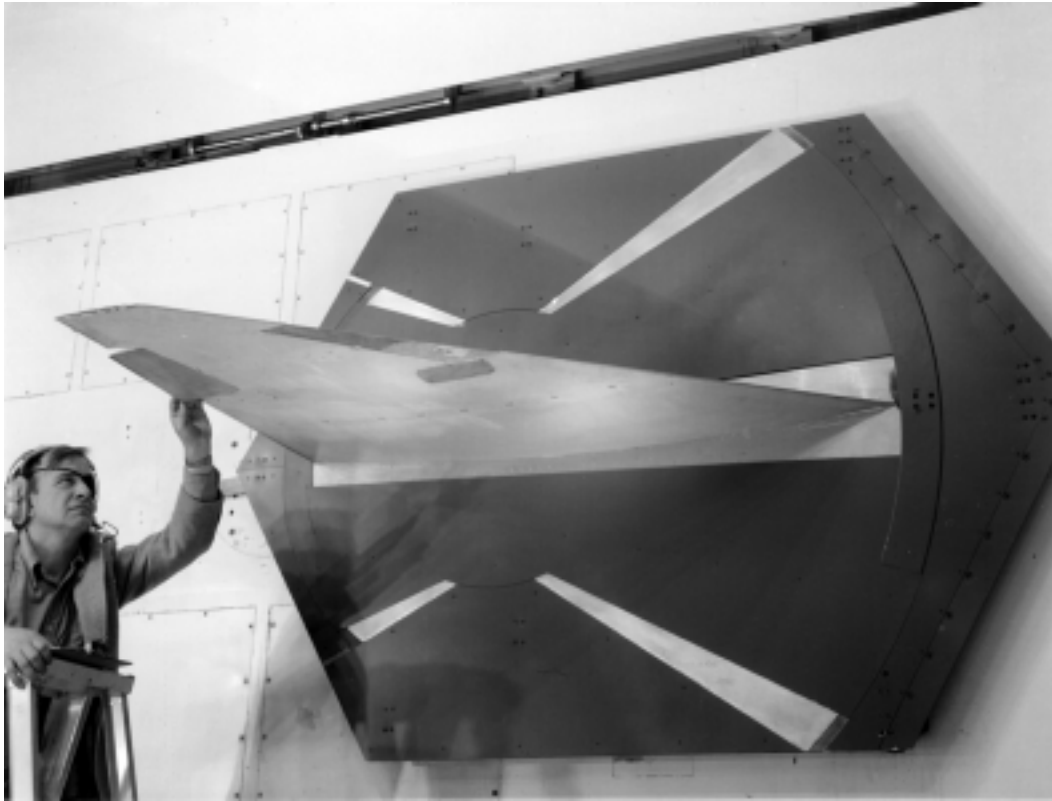

Figure 1. Clipped delta wing installed in wind tunnel.

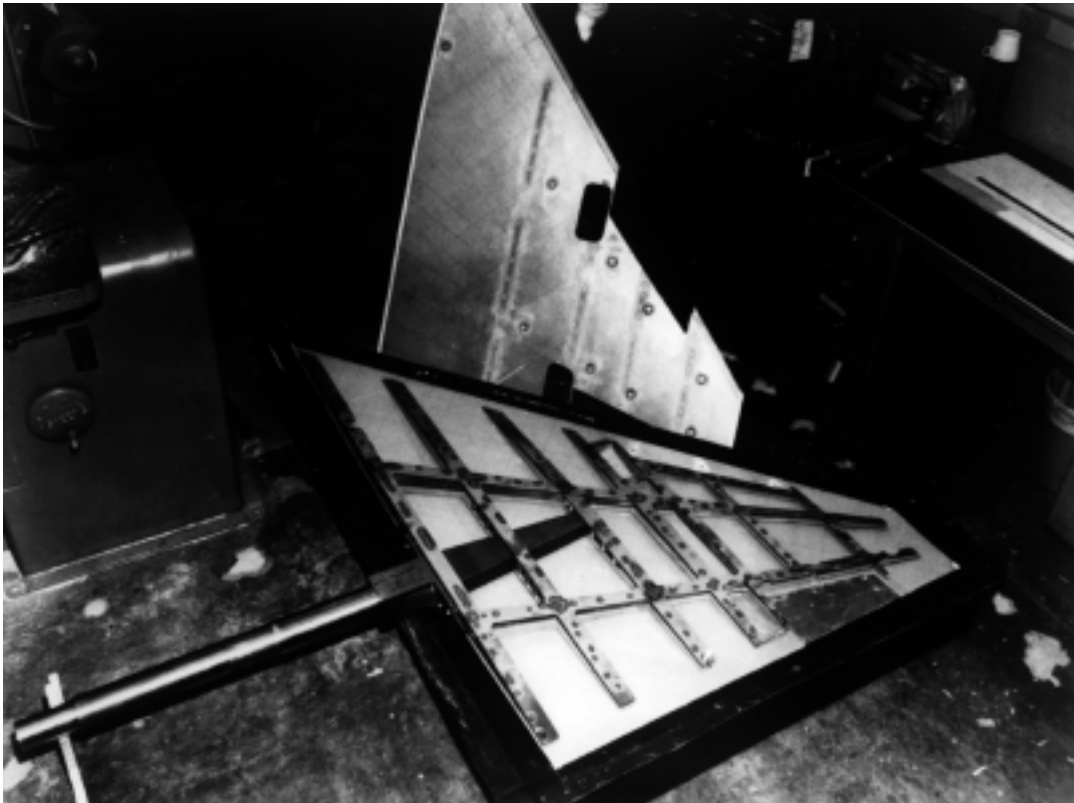

Figure 2. Construction of clipped delta wing.

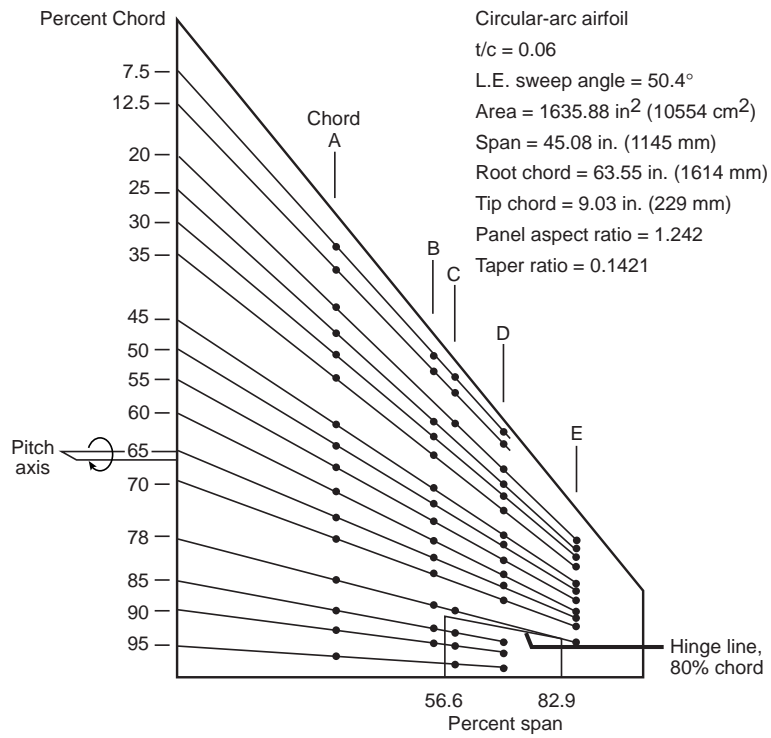

Figure 3. Planform geometry and instrumentation layout.

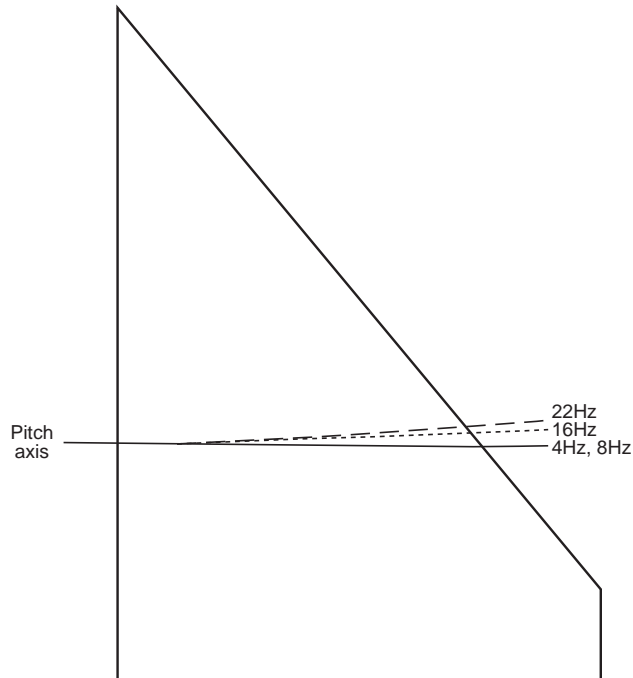
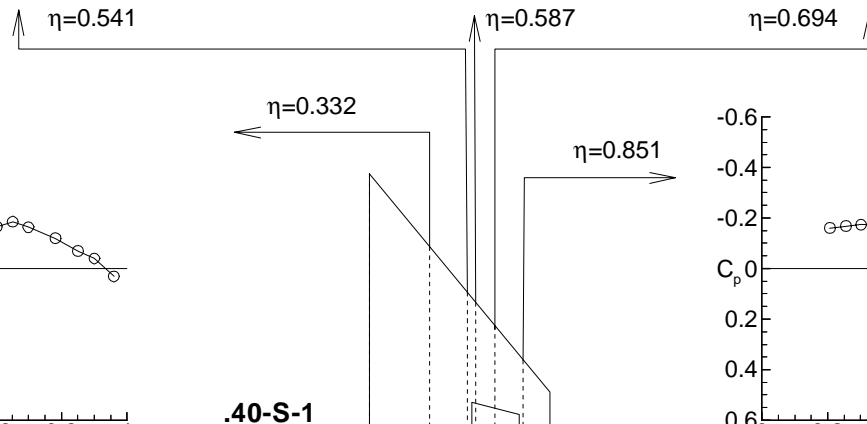
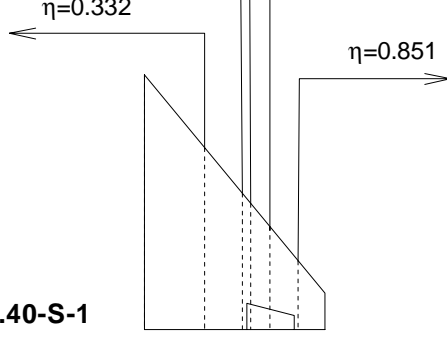
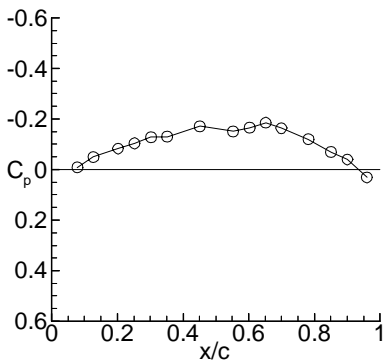
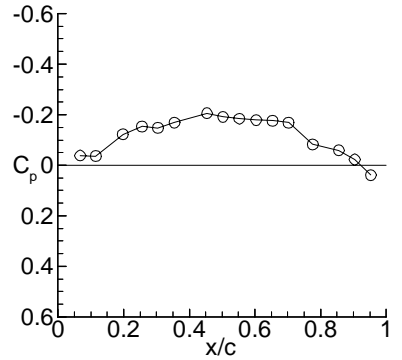
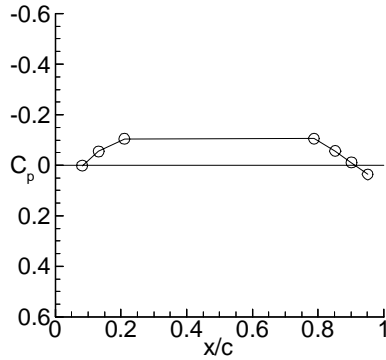
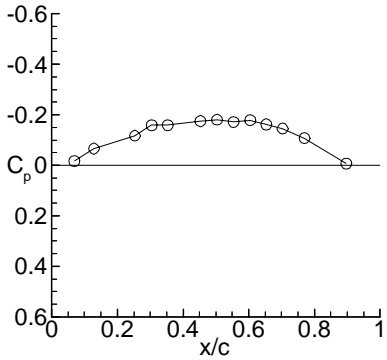

Figure 4. Node lines for test frequencies in still air.

.40-S-1

MACH	q psf	T_o deg R	H psf	ALPHA o deg	THETA deg	DELTA deg	RN
0.399	82.7	547.5	1004.2	0.05	0.00	0.00	9.35 *10**6

y/s= 0.332			y/s= 0.541			y/s= 0.587			y/s= 0.694			y/s= 0.851		
x/c	Cpu	Cpl	x/c	Cpu	Cpl	x/c	Cpu	Cpl	x/c	Cpu	Cpl	x/c	Cpu	Cpl
.0778	-.0087		.0687	-.0171		.0818	0.0021		.0675	-.0380		.2070	-.1606	
.1264	-.0499		.1282	-.0654		.1318	-.0548		.1151	-.0360		.2559	-.1677	
.2020	-.0835		.2529	-.1165		.2099	-.1045		.1980	-.1223		.3016	-.1735	
.2523	-.1039		.3041	-.1585		.7875	-.1054		.2559	-.1536		.3537	-.1713	
.3023	-.1277		.3531	-.1591		.8522	-.0568		.3041	-.1480		.4583	-.2187	
.3519	-.1302		.4530	-.1746		.9017	-.0111		.3545	-.1692		.5562	-.1981	
.4510	-.1715		.5036	-.1796		.9514	0.0357		.4537	-.2052		.6074	-.1778	
.5523	-.1513		.5534	-.1715					.5025	-.1918		.6577	-.1767	
.6025	-.1655		.6040	-.1781					.5527	-.1844		.7071	-.1570	
.6515	-.1848		.6528	-.1619					.6038	-.1793		.7975	-.0925	
.6991	-.1643		.7030	-.1449					.6538	-.1761				
.7813	-.1205		.7694	-.1072					.7025	-.1683				
.8505	-.0693		.8967	-.0068					.7754	-.0830				
.9001	-.0404								.8553	-.0589				
.9596	0.0306								.9037	-.0225				
									.9526	0.0391				



(a) Test case 9E1 (point .40-S-1)
Figure 5. Static test cases.

.88-S-1

MACH	q psf	To deg R	H psf	ALPHAO deg	THETA deg	DELTA deg	RN
0.883	185.0	557.9	664.7	0.05	0.00	0.00	9.79 *10**6

y/s= 0.332			y/s= 0.541			y/s= 0.587			y/s= 0.694			y/s= 0.851		
x/c	Cpu	Cpl	x/c	Cpu	Cpl	x/c	Cpu	Cpl	x/c	Cpu	Cpl	x/c	Cpu	Cpl
.0778	0.0129		.0687	-.0024		.0818	0.0134		.0675	-.0573		.2070	-.2601	
.1264	-.0387		.1282	-.0796		.1318	-.0634		.1151	-.0593		.2559	-.2811	
.2020	-.0854		.2529	-.1546		.2099	-.1465		.1980	-.1739		.3016	-.2757	
.2523	-.1158		.3041	-.2222		.7875	-.1580		.2559	-.2315		.3537	-.2924	
.3023	-.1582		.3531	-.2383		.8522	-.0842		.3041	-.2399		.4583	-.3823	
.3519	-.1620		.4530	-.2805		.9017	0.0045		.3545	-.2762		.5562	-.3760	
.4510	-.2440		.5036	-.3066		.9514	0.0852		.4537	-.3545		.6074	-.3218	
.5523	-.2405		.5534	-.3018					.5025	-.3482		.6577	-.2911	
.6025	-.2843		.6040	-.3225					.5527	-.3403		.7071	-.2423	
.6515	-.3385		.6528	-.3155					.6038	-.3379		.7975	-.1120	
.6991	-.2958		.7030	-.2779					.6538	-.3279				
.7813	-.2194		.7694	-.1803					.7025	-.3024				
.8505	-.1116		.8967	0.0020					.7754	-.1276				
.9001	-.0472								.8553	-.0779				
.9596	0.0666								.9037	-.0013				
									.9526	0.0880				

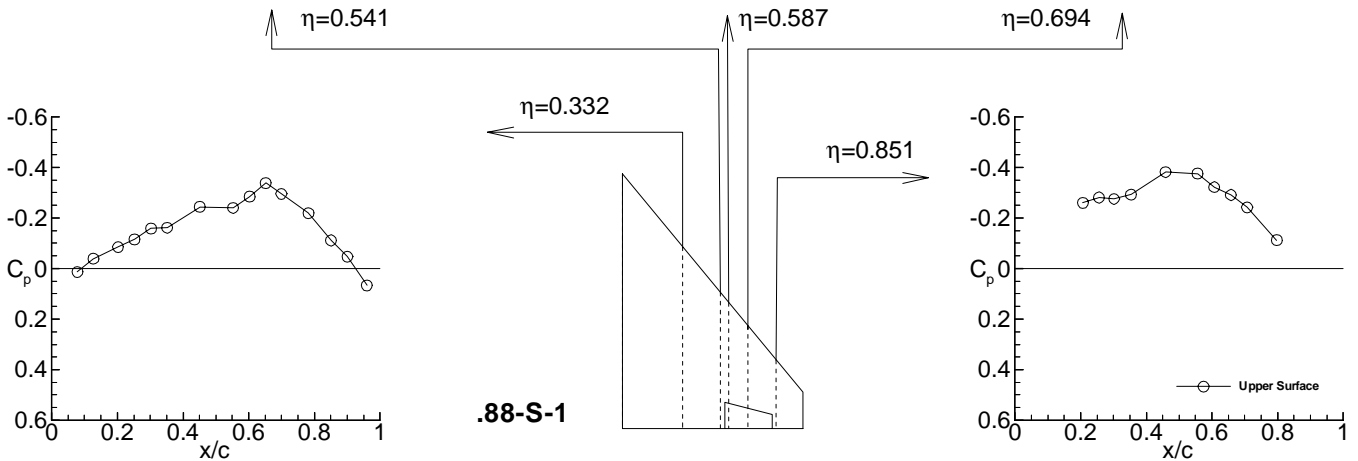
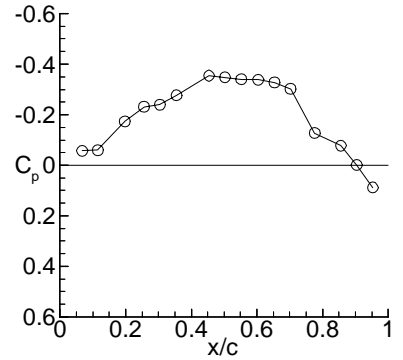
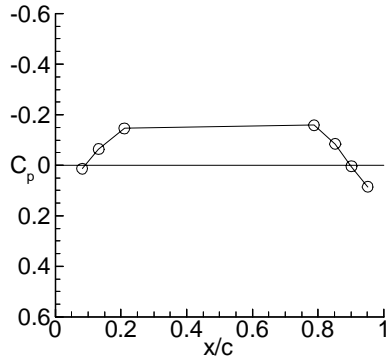
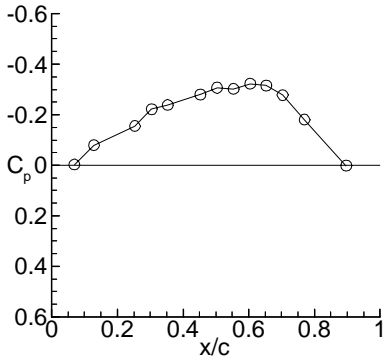

(b) Test case 9E2 (point .88-S-1)
Figure 5. Continued.

.90-S-1

MACH	q	T_o	H	ALPHA o	THETA	DELTA	RN
	psf	deg R	psf	deg	deg	deg	
0.899	191.2	565.3	651.8	0.05	0.00	0.00	9.77 *10**6

y/s= 0.332			y/s= 0.541			y/s= 0.587			y/s= 0.694			y/s= 0.851		
x/c	Cpu	Cpl	x/c	Cpu	Cpl	x/c	Cpu	Cpl	x/c	Cpu	Cpl	x/c	Cpu	Cpl
.0778	0.0217		.0687	0.0049		.0818	0.0229		.0675	-.0528		.2070	-.2689	
.1264	-.0318		.1282	-.0788		.1318	-.0596		.1151	-.0572		.2559	-.3260	
.2020	-.0802		.2529	-.1548		.2099	-.1477		.1980	-.1748		.3016	-.2912	
.2523	-.1134		.3041	-.2251		.7875	-.1491		.2559	-.2408		.3537	-.3057	
.3023	-.1580		.3531	-.2484		.8522	-.0710		.3041	-.2481		.4583	-.4098	
.3519	-.1620		.4530	-.2859		.9017	0.0186		.3545	-.2905		.5562	-.4368	
.4510	-.2456		.5036	-.3258		.9514	0.0988		.4537	-.3831		.6074	-.3943	
.5523	-.2424		.5534	-.3261					.5025	-.3628		.6577	-.3388	
.6025	-.3011		.6040	-.3542					.5527	-.3760		.7071	-.2408	
.6515	-.3778		.6528	-.3646					.6038	-.3990		.7975	-.0879	
.6991	-.3374		.7030	-.3350					.6538	-.3987				
.7813	-.2514		.7694	-.1980					.7025	-.3588				
.8505	-.1069		.8967	0.0138					.7754	-.1191				
.9001	-.0362								.8553	-.0617				
.9596	0.0812								.9037	0.0126				
									.9526	0.0999				

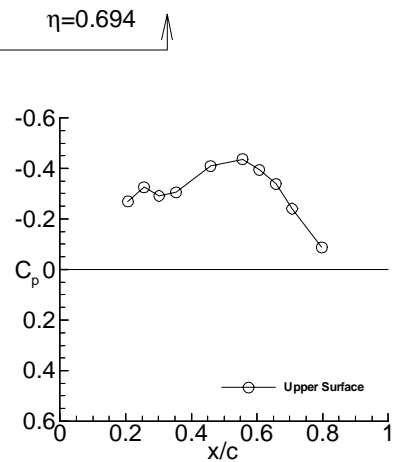
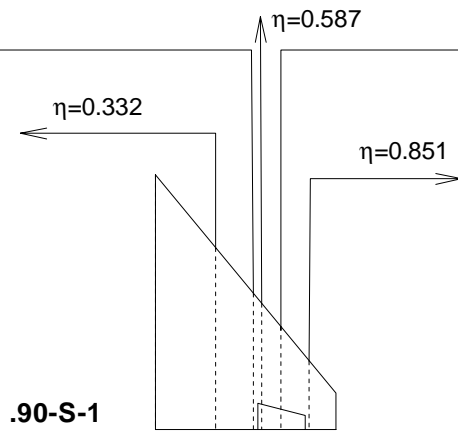
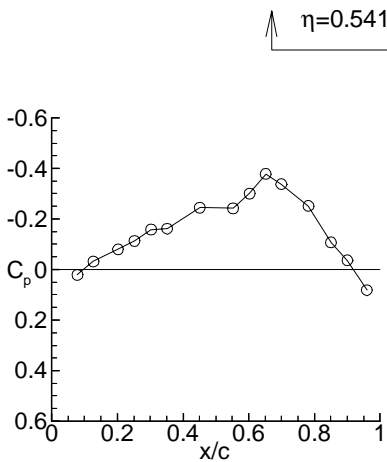
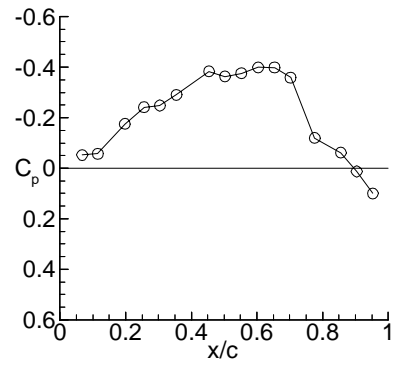
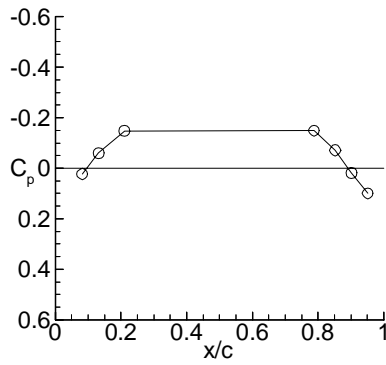
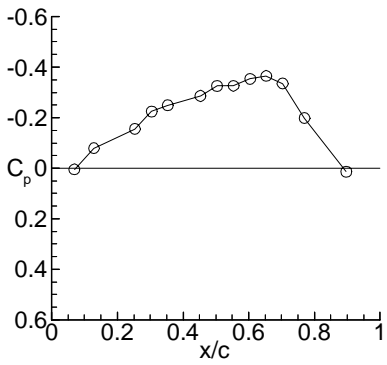

(c) Test case 9E3 (point .90-S-1)
Figure 5. Continued.

.92-S-1

MACH	q psf	T_o deg R	H psf	ALPHA o deg	THETA deg	DELTA deg	RN
0.921	193.8	541.7	643.0	0.05	0.00	0.00	10.35 *10**6

y/s= 0.332			y/s= 0.541			y/s= 0.587			y/s= 0.694			y/s= 0.851		
x/c	Cpu	Cpl	x/c	Cpu	Cpl	x/c	Cpu	Cpl	x/c	Cpu	Cpl	x/c	Cpu	Cpl
.0778	0.0217		.0687	0.0082		.0818	0.0191		.0675	-.0474		.2070	-.2554	
.1264	-.0319		.1282	-.0762		.1318	-.0570		.1151	-.0568		.2559	-.3334	
.2020	-.0808		.2529	-.1519		.2099	-.1505		.1980	-.1757		.3016	-.3093	
.2523	-.1094		.3041	-.2232		.7875	-.2268		.2559	-.2463		.3537	-.3472	
.3023	-.1542		.3531	-.2526		.8522	-.0447		.3041	-.2500		.4583	-.4356	
.3519	-.1557		.4530	-.3013		.9017	0.0449		.3545	-.3058		.5562	-.4798	
.4510	-.2504		.5036	-.3205		.9514	0.1231		.4537	-.3916		.6074	-.4883	
.5523	-.2577		.5534	-.3423					.5025	-.3836		.6577	-.5421	
.6025	-.3150		.6040	-.3669					.5527	-.3955		.7071	-.5585	
.6515	-.3970		.6528	-.4097					.6038	-.4273		.7975	-.0423	
.6991	-.3945		.7030	-.4424					.6538	-.4884				
.7813	-.3789		.7694	-.3641					.7025	-.5344				
.8505	-.1054		.8967	0.0296					.7754	-.2269				
.9001	-.0228								.8553	-.0245				
.9596	0.0899								.9037	0.0519				
									.9526	0.1326				

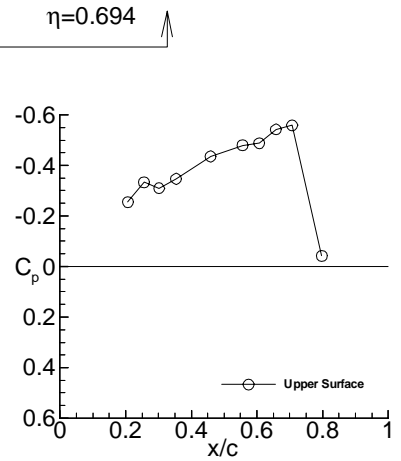
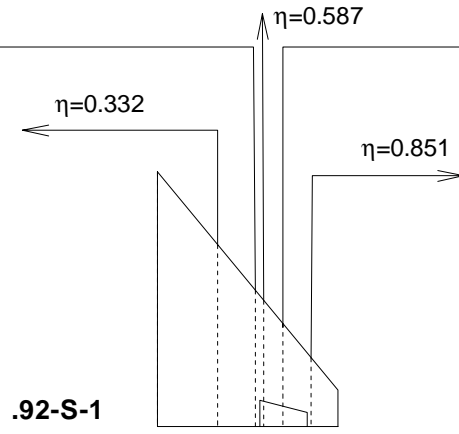
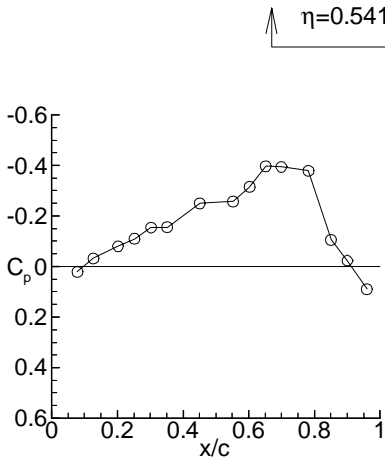
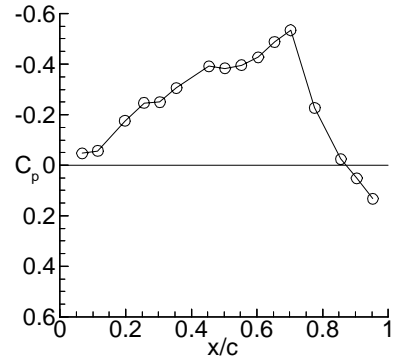
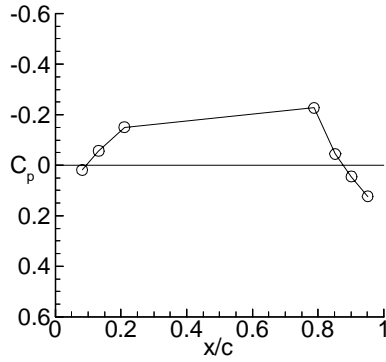
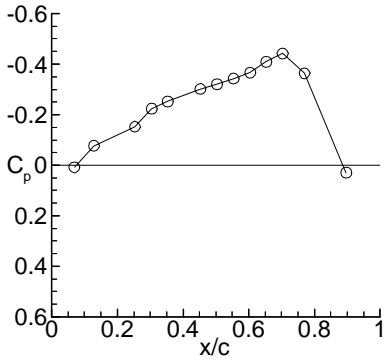

(d) Test case 9E4 (point .92-S-1)
Figure 5. Continued.

.94-S-1

MACH	q psf	To deg R	H psf	ALPHAO deg	THETA deg	DELTA deg	RN
0.944	203.7	562.5	658.6	0.05	0.00	0.00	10.07 *10**6

y/s= 0.332			y/s= 0.541			y/s= 0.587			y/s= 0.694			y/s= 0.851		
x/c	Cpu	Cpl	x/c	Cpu	Cpl	x/c	Cpu	Cpl	x/c	Cpu	Cpl	x/c	Cpu	Cpl
.0778	0.0308		.0687	0.0127		.0818	0.0247		.0675	-.0634		.2070	-.2318	
.1264	-.0194		.1282	-.0748		.1318	-.0529		.1151	-.0441		.2559	-.3292	
.2020	-.0646		.2529	-.1391		.2099	-.1415		.1980	-.1427		.3016	-.3091	
.2523	-.0975		.3041	-.2057		.7875	-.5282		.2559	-.2259		.3537	-.3454	
.3023	-.1437		.3531	-.2389		.8522	-.2280		.3041	-.2341		.4583	-.4238	
.3519	-.1407		.4530	-.3048		.9017	0.0243		.3545	-.2999		.5562	-.4757	
.4510	-.2367		.5036	-.3202		.9514	0.1309		.4537	-.3829		.6074	-.4682	
.5523	-.2463		.5534	-.3378					.5025	-.3786		.6577	-.5219	
.6025	-.3079		.6040	-.3610					.5527	-.3794		.7071	-.5971	
.6515	-.3965		.6528	-.3961					.6038	-.4140		.7975	-.4958	
.6991	-.3988		.7030	-.4429					.6538	-.4682				
.7813	-.4019		.7694	-.4591					.7025	-.5219				
.8505	-.2776		.8967	0.0103					.7754	-.5178				
.9001	-.0161								.8553	-.1340				
.9596	0.1086								.9037	0.0448				
									.9526	0.1434				

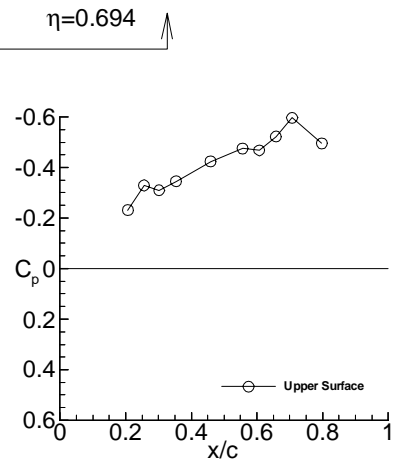
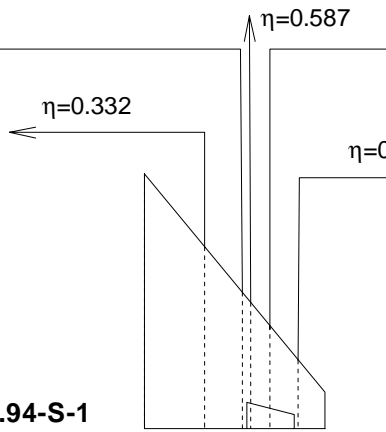
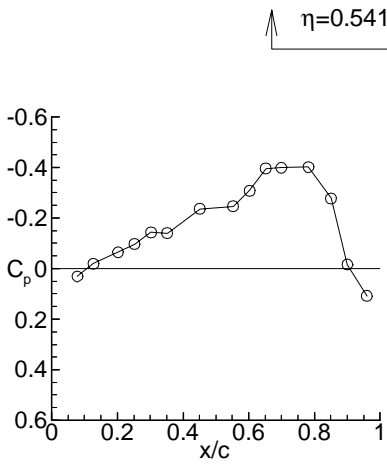
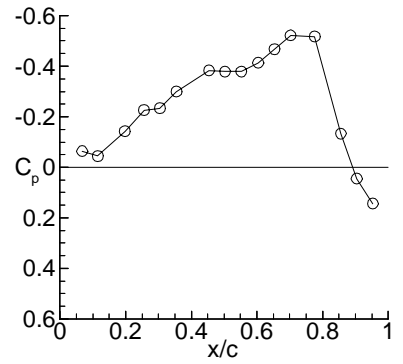
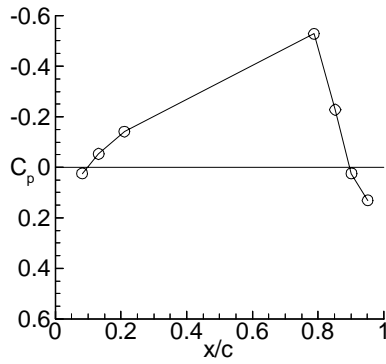
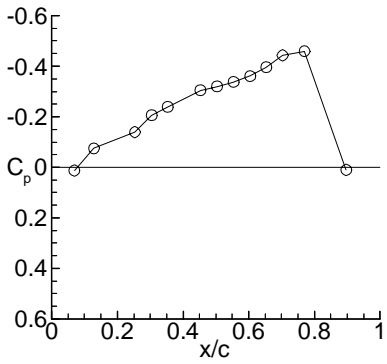

(e) Test case 9E5 (point .94-S-1)
Figure 5. Continued.

.96-S-1

MACH	q	T_o	H	ALPHA o	THETA	DELTA	RN
	psf	deg R	psf	deg	deg	deg	
0.965	197.1	551.9	622.7	0.00	0.00	0.00	9.81 *10**6

y/s= 0.332			y/s= 0.541			y/s= 0.587			y/s= 0.694			y/s= 0.851		
x/c	Cpu	Cpl	x/c	Cpu	Cpl	x/c	Cpu	Cpl	x/c	Cpu	Cpl	x/c	Cpu	Cpl
.0778	0.0406		.0687	0.0168		.0818	0.0000		.0675	-.0292		.2070	-.2062	
.1264	-.0101		.1282	-.0619		.1318	0.0292		.1151	-.0256		.2559	-.3023	
.2020	-.0563		.2529	-.1240		.2099	-.0438		.1980	-.1202		.3016	-.2895	
.2523	-.0879		.3041	-.1880		.7875	-.1260		.2559	-.2021		.3537	-.3265	
.3023	-.1357		.3531	-.2271		.8522	-.5373		.3041	-.2050		.4583	-.3903	
.3519	-.1331		.4530	-.2880		.9017	-.4922		.3545	-.2674		.5562	-.4357	
.4510	-.2233		.5036	-.3101		.9514	-.1113		.4537	-.3558		.6074	-.4289	
.5523	-.2347		.5534	-.3237					.5025	-.3544		.6577	-.4752	
.6025	-.2917		.6040	-.3481					.5527	-.3592		.7071	-.5483	
.6515	-.3782		.6528	-.3862					.6038	-.3839		.7975	-.5919	
.6991	-.3859		.7030	-.4291					.6538	-.4336				
.7813	-.4142		.7694	-.4497					.7025	-.4804				
.8505	-.3854		.8967	-.1723					.7754	-.4802				
.9001	-.2732								.8553	-.5194				
.9596	0.0737								.9037	-.1035				
									.9526	0.0569				

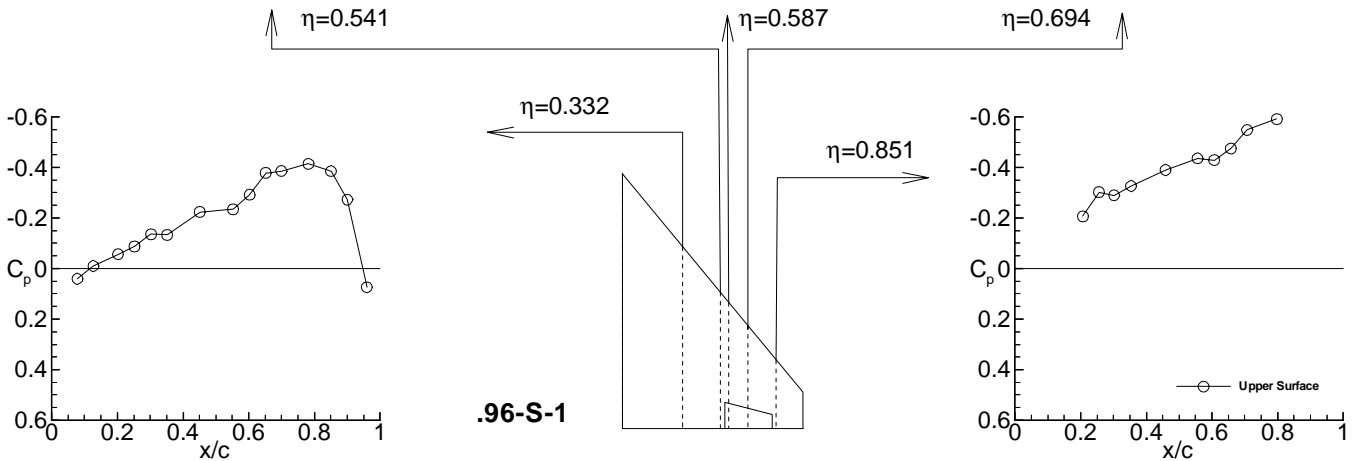
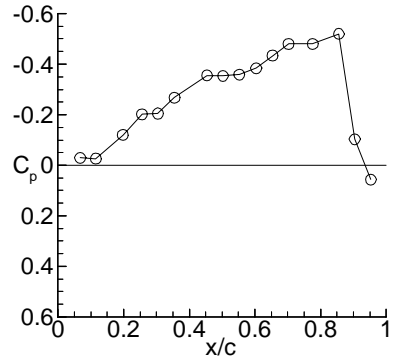
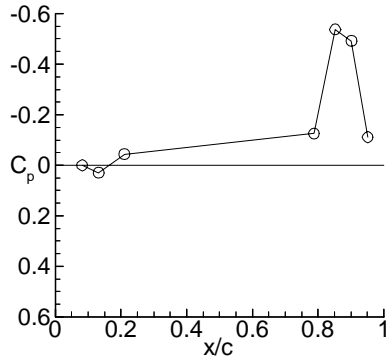
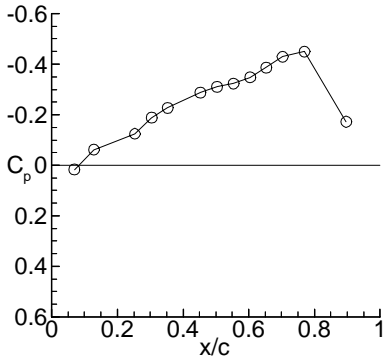

(f) Test case 9E6 (point .96-S-1)
Figure 5. Continued.

1.12-S-1

MACH	q	T_o	H	ALPHA o	THETA	DELTA	RN
	psf	deg R	psf	deg	deg	deg	
1.120	230.4	572.5	641.3	0.00	0.00	0.00	9.68 *10**6

y/s= 0.332			y/s= 0.541			y/s= 0.587			y/s= 0.694			y/s= 0.851		
x/c	Cpu	Cpl	x/c	Cpu	Cpl	x/c	Cpu	Cpl	x/c	Cpu	Cpl	x/c	Cpu	Cpl
.0778	0.0390		.0687	0.0788		.0818	0.1764		.0675	0.1085		.2070	-.0404	
.1264	0.0009		.1282	0.0835		.1318	0.0641		.1151	0.1227		.2559	-.1160	
.2020	-.0850		.2529	0.0226		.2099	0.0217		.1980	0.0268		.3016	-.1110	
.2523	-.0297		.3041	-.0251		.7875	-.3866		.2559	-.0488		.3537	-.1521	
.3023	0.0019		.3531	-.0850		.8522	-.3064		.3041	-.0561		.4583	-.2113	
.3519	-.0075		.4530	-.1552		.9017	-.3195		.3545	-.1147		.5562	-.2708	
.4510	-.1001		.5036	-.1865		.9514	-.3628		.4537	-.2013		.6074	-.2705	
.5523	-.1053		.5534	-.1931					.5025	-.2034		.6577	-.2948	
.6025	-.1419		.6040	-.1813					.5527	-.2183		.7071	-.3437	
.6515	-.2208		.6528	-.2036					.6038	-.2191		.7975	-.3818	
.6991	-.2397		.7030	-.2572					.6538	-.2427				
.7813	-.2473		.7694	-.2931					.7025	-.2738				
.8505	-.2820		.8967	-.2820					.7754	-.2824				
.9001	-.3232								.8553	-.3126				
.9596	-.3378								.9037	-.3498				
									.9526	-.3612				

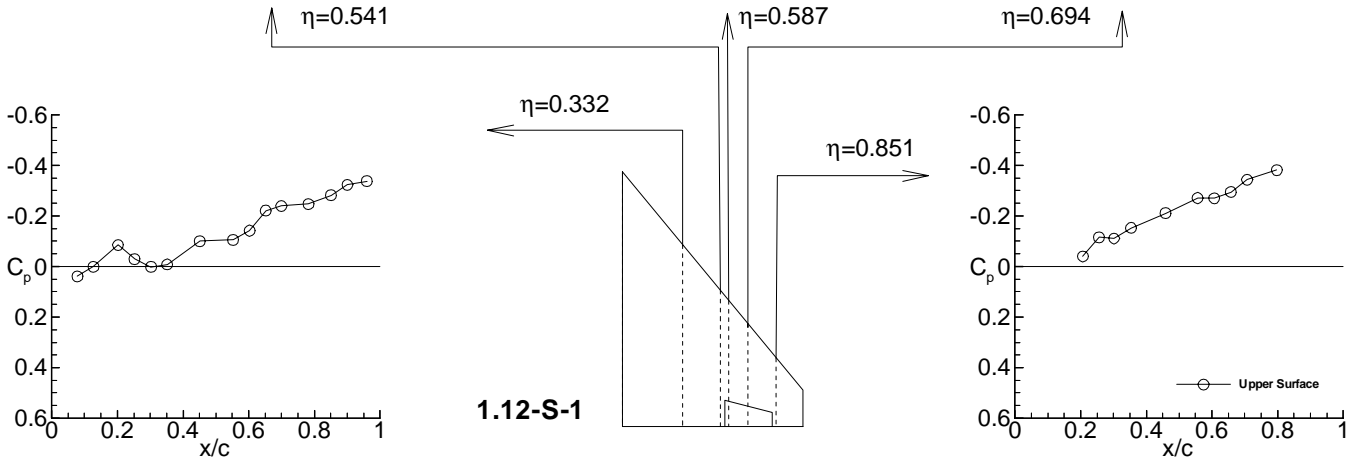
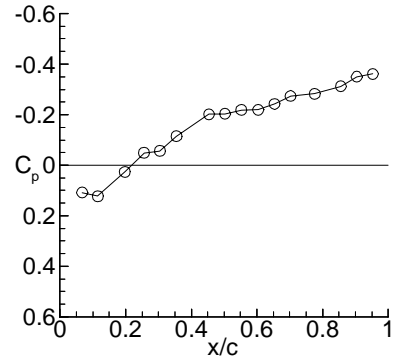
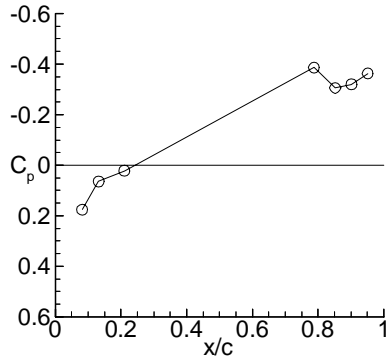
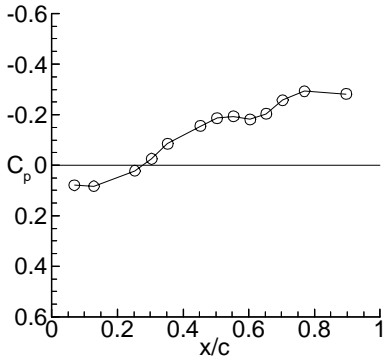

(g) Test case 9E7 (point 1.12-S-1)
Figure 5. Continued.

.40-S-6

MACH	q psf	T_o deg R	H psf	ALPHA $_o$ deg	THETA deg	DELTA deg	RN
0.400	76.4	520.7	917.9	1.03	0.00	0.00	9.21 *10**6

y/s= 0.332			y/s= 0.541			y/s= 0.587			y/s= 0.694			y/s= 0.851		
x/c	Cpu	Cpl	x/c	Cpu	Cpl	x/c	Cpu	Cpl	x/c	Cpu	Cpl	x/c	Cpu	Cpl
.0778	-.0606	0.0350	.0687	-.0849	0.0422	.0818	-.0679	0.0611	.0675	-.1157	0.0362	.2070	-.2159	-.1115
.1264	-.0960	-.0171	.1282	-.1202	-.0186	.1318	-.1121	-.0071	.1151	-.1060	0.0207	.2559	-.2203	-.1270
.2020	-.1259	-.0615	.2529	-.1554	-.0855	.2099	-.1493	-.0694	.1980	-.1751	-.0793	.3016	-.2205	-.1386
.2523	-.1391	-.0815	.3041	-.1940	-.1329	.7875	-.1168	-.1076	.2559	-.1967	-.1174	.3537	-.2113	-.1414
.3023	-.1616	-.1103	.3531	-.1916	-.1360	.8522	-.0643	-.0557	.3041	-.1884	-.1157	.4583	-.2509	-.1990
.3519	-.1636	-.1167	.4530	-.2015	-.1566	.9017	-.0142	-.0078	.3545	-.2072	-.1431	.5562	-.2201	-.1818
.4510	-.1991	-.1616	.5036	-.2062	-.1675	.9514	0.0354	0.0366	.4537	-.2348	-.1845	.6074	-.1982	-.1668
.5523	-.1739	-.1438	.5534	-.1919	-.1579				.5025	-.2195	-.1754	.6577	-.1943	-.1690
.6025	-.1867	-.1591	.6040	-.1976	-.1689				.5527	-.2092	-.1719	.7071	-.1679	-.1489
.6515	-.2023	-.1816	.6528	-.1795	-.1548				.6038	-.1966	-.1650	.7975	-.1052	-.0943
.6991	-.1836	-.1632	.7030	-.1608	-.1399				.6538	-.1959	-.1700			
.7813	-.1325	-.1206	.7694	-.1186	-.1041				.7025	-.1838	-.1641			
.8505	-.0784	-.0719	.8967	-.0109	-.0028				.7754	-.1025	-.0908			
.9001	-.0491	-.0453							.8553	-.0634	-.0537			
.9596	0.0211	0.0217							.9037	-.0222	-.0171			
									.9526	0.0420	0.0428			

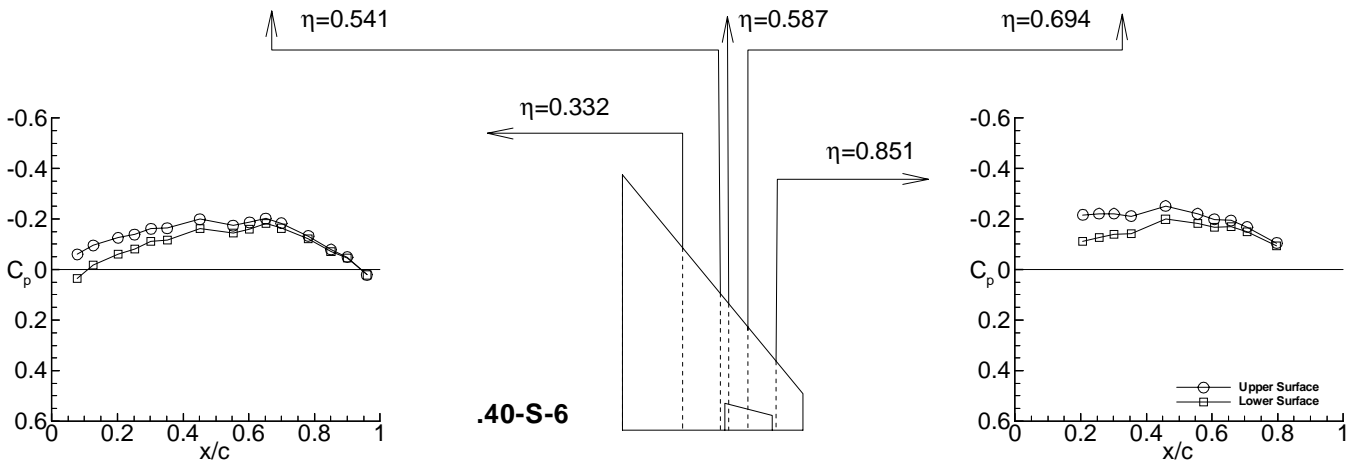
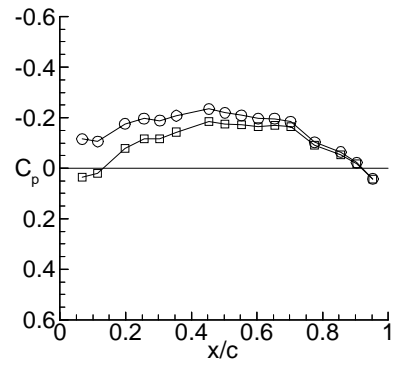
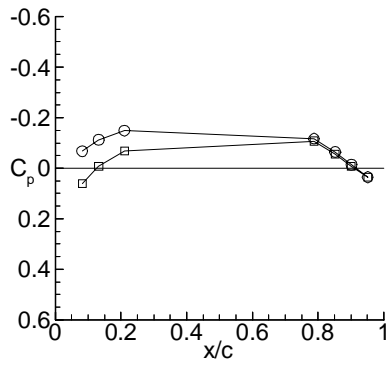
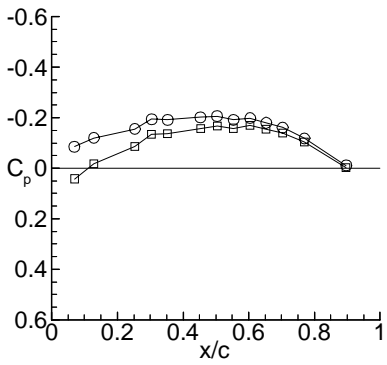

(h) Test case 9E8 (point .40-S-6)
Figure 5. Continued.

.90-S-5

MACH	α	To	H	ALPHAo	THETA	DELTA	RN
	psf	deg R	psf	deg	deg	deg	
0.909	199.7	565.7	673.5	0.99	0.00	0.00	10.11 *10**6

y/s= 0.332			y/s= 0.541			y/s= 0.587			y/s= 0.694			y/s= 0.851		
x/c	Cpu	Cpl	x/c	Cpu	Cpl	x/c	Cpu	Cpl	x/c	Cpu	Cpl	x/c	Cpu	Cpl
.0778	-.0262	0.0596	.0687	-.0690	0.0538	.0818	-.0645	0.0574	.0675	-.1294	0.0129	.2070	-.3019	-.1935
.1264	-.0691	0.0054	.1282	-.1348	-.0329	.1318	-.1268	-.0199	.1151	-.1243	-.0012	.2559	-.3715	-.2193
.2020	-.1102	-.0437	.2529	-.1952	-.1177	.2099	-.1917	-.0993	.1980	-.2125	-.1118	.3016	-.3500	-.2201
.2523	-.1396	-.0791	.3041	-.2543	-.1866	.7875	-.1370	-.1512	.2559	-.2745	-.1813	.3537	-.3783	-.2444
.3023	-.1813	-.1234	.3531	-.2847	-.2077	.8522	-.0641	-.0769	.3041	-.2789	-.1907	.4583	-.4422	-.3401
.3519	-.1813	-.1321	.4530	-.3320	-.2548	.9017	0.0198	0.0115	.3545	-.3310	-.2317	.5562	-.4631	-.3798
.4510	-.2716	-.2225	.5036	-.3444	-.2852	.9514	0.0987	0.0900	.4537	-.4056	-.3191	.6074	-.3721	-.3422
.5523	-.2809	-.2219	.5534	-.3688	-.2911				.5025	-.4022	-.3126	.6577	-.2869	-.3006
.6025	-.3365	-.2759	.6040	-.3902	-.3178				.5527	-.4019	-.3218	.7071	-.2038	-.2310
.6515	-.4083	-.3421	.6528	-.4118	-.3209				.6038	-.4349	-.3374	.7975	-.0827	-.0986
.6991	-.3860	-.3046	.7030	-.3550	-.2967				.6538	-.4644	-.3366			
.7813	-.2561	-.2384	.7694	-.1759	-.1819				.7025	-.3958	-.3200			
.8505	-.0940	-.1083	.8967	0.0129	0.0079				.7754	-.0879	-.1127			
.9001	-.0218	-.0410							.8553	-.0423	-.0702			
.9596	0.0903	0.0756							.9037	0.0209	0.0013			
									.9526	0.1017	0.0858			

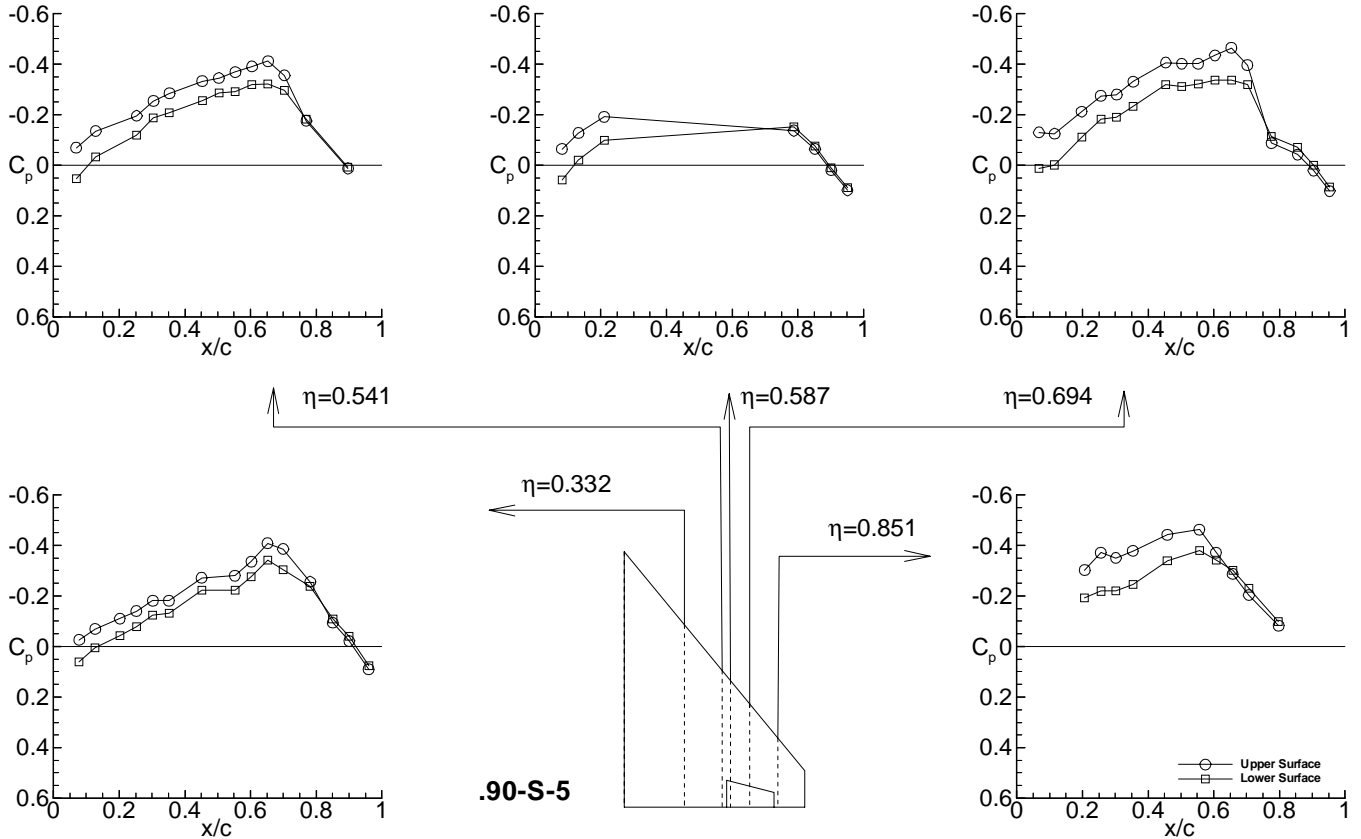

(i) Test case 9E9 (point .90-S-5)
Figure 5. Continued.

.94-S-6

MACH	q psf	T_o deg R	H psf	ALPHA o deg	THETA deg	DELTA deg	RN
0.943	199.9	557.1	647.4	0.97	0.00	0.00	10.04 *10**6

y/s= 0.332			y/s= 0.541			y/s= 0.587			y/s= 0.694			y/s= 0.851		
x/c	Cpu	Cpl	x/c	Cpu	Cpl	x/c	Cpu	Cpl	x/c	Cpu	Cpl	x/c	Cpu	Cpl
.0778	-.0158	0.0757	.0687	-.0517	0.0726	.0818	-.0424	0.0896	.0675	-.1383	0.0304	.2070	-.3004	-.1898
.1264	-.0574	0.0206	.1282	-.1249	-.0156	.1318	-.1050	0.0013	.1151	-.1135	0.0111	.2559	-.3940	-.2685
.2020	-.0995	-.0284	.2529	-.1779	-.1009	.2099	-.1851	-.0919	.1980	-.1977	-.1072	.3016	-.3716	-.2358
.2523	-.1285	-.0637	.3041	-.2363	-.1723	.7875	-.5582	-.4994	.2559	-.2727	-.1903	.3537	-.4139	-.2762
.3023	-.1735	-.1101	.3531	-.2708	-.2069	.8522	-.1636	-.2868	.3041	-.2709	-.1947	.4583	-.4777	-.3664
.3519	-.1694	-.1100	.4530	-.3348	-.2673	.9017	0.0316	0.0128	.3545	-.3394	-.2537	.5562	-.5310	-.4248
.4510	-.2606	-.2082	.5036	-.3546	-.2850	.9514	0.1340	0.1233	.4537	-.4323	-.3389	.6074	-.5161	-.4330
.5523	-.2704	-.2231	.5534	-.3628	-.3084				.5025	-.4228	-.3323	.6577	-.5564	-.4890
.6025	-.3350	-.2812	.6040	-.3926	-.3286				.5527	-.4323	-.3419	.7071	-.6272	-.5743
.6515	-.4160	-.3717	.6528	-.4280	-.3728				.6038	-.4543	-.3807	.7975	-.3637	-.6065
.6991	-.4284	-.3689	.7030	-.4704	-.4149				.6538	-.5088	-.4356			
.7813	-.4348	-.3779	.7694	-.4916	-.4311				.7025	-.5531	-.4897			
.8505	-.2559	-.3522	.8967	0.0125	-.0133				.7754	-.5530	-.4871			
.9001	-.0082	-.0473							.8553	-.1171	-.3281			
.9596	0.1140	0.1016							.9037	0.0482	0.0075			
									.9526	0.1420	0.1256			

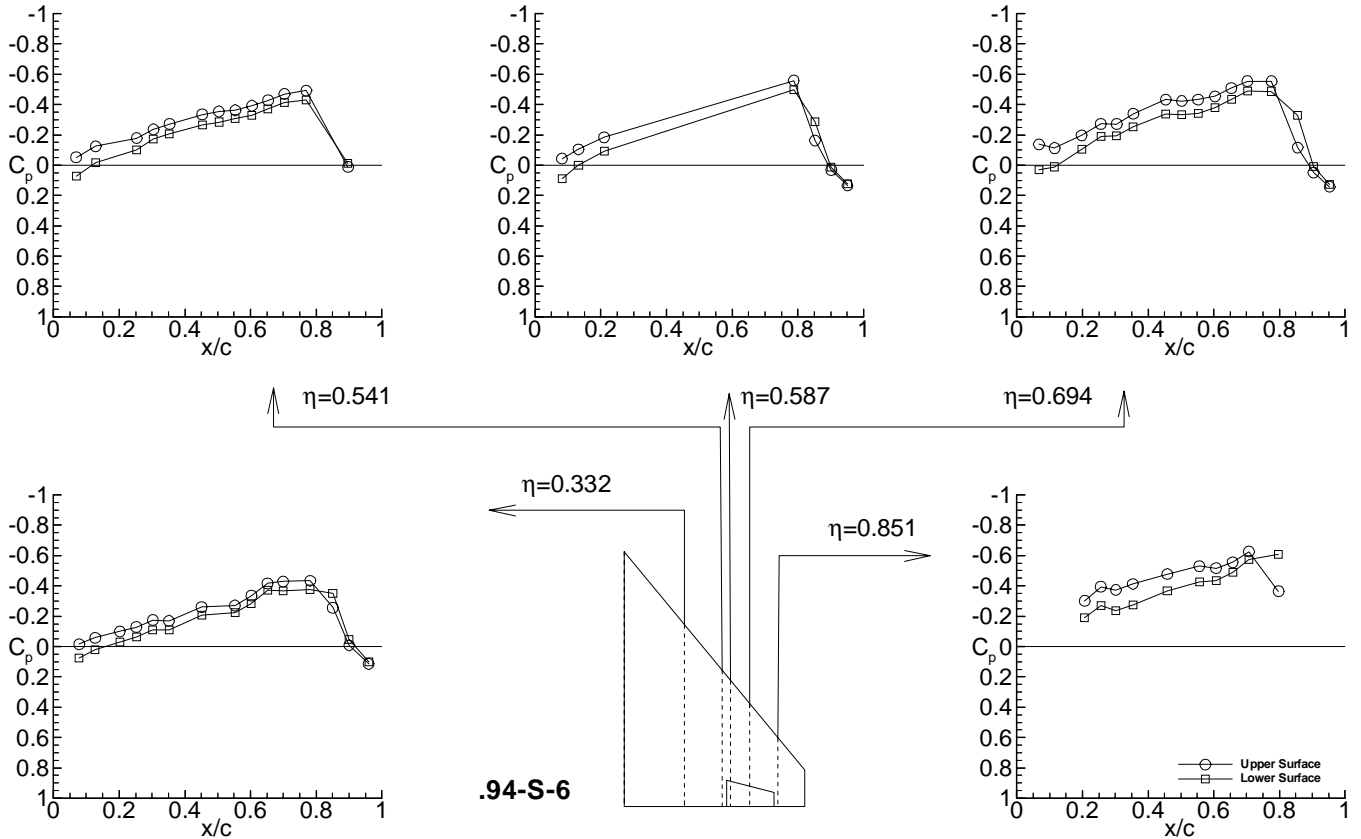

(j) Test case 9E10 (point .94-S-6)
Figure 5. Continued.

1.12-S-6

MACH	q psf	To deg R	H psf	ALPHAo deg	THETA deg	DELTA deg	RN
1.120	231.7	573.2	643.0	0.99	0.00	0.00	9.70 *10**6

y/s= 0.332			y/s= 0.541			y/s= 0.587			y/s= 0.694			y/s= 0.851		
x/c	Cpu	Cpl	x/c	Cpu	Cpl	x/c	Cpu	Cpl	x/c	Cpu	Cpl	x/c	Cpu	Cpl
.0778	0.0002	0.0687	.0687	-.0344	0.1603	.0818	0.1021	0.2178	.0675	0.0747	0.1675	.2070	-.1112	0.0090
.1264	-.0359	0.0310	.1282	0.0308	0.1083	.1318	0.0254	0.1111	.1151	0.0639	0.1652	.2559	-.1755	-.0665
.2020	-.1181	-.0455	.2529	-.0189	0.0472	.2099	-.0196	0.0600	.1980	-.0265	0.0651	.3016	-.1644	-.0628
.2523	-.0724	-.0126	.3041	-.0689		.7875	-.3982	-.3602	.2559	-.0993	-.0136	.3537	-.1946	-.1025
.3023	-.0358	0.0219	.3531	-.1262	-.0563	.8522	-.3249	-.2861	.3041	-.1080	-.0190	.4583	-.2489	-.1624
.3519	-.0508	0.0087	.4530	-.1788	-.1177	.9017	-.3357	-.3083	.3545	-.1590	-.0793	.5562	-.3082	-.2244
.4510	-.1117	-.0751	.5036	-.2067	-.1523	.9514	-.3716	-.3500	.4537	-.2337	-.1669	.6074	-.3069	-.2226
.5523	-.1184	-.0738	.5534	-.2185	-.1547				.5025	-.2343	-.1695	.6577	-.3305	-.2430
.6025	-.1543	-.1101	.6040	-.2113	-.1435				.5527	-.2519	-.1790	.7071	-.3696	-.2866
.6515	-.2284	-.1972	.6528	-.2181	-.1827				.6038	-.2546	-.1742	.7975	-.3998	-.3446
.6991	-.2506	-.2146	.7030	-.2712	-.2370				.6538	-.2662	-.1952			
.7813	-.2627	-.2268	.7694	-.3125	-.2711				.7025	-.2943	-.2469			
.8505	-.2916	-.2619	.8967	-.2984	-.2639				.7754	-.2918	-.2542			
.9001	-.3354	-.3002							.8553	-.3197	-.2909			
.9596	-.3547	-.3237							.9037	-.3595	-.3263			
									.9526	-.3793	-.3481			

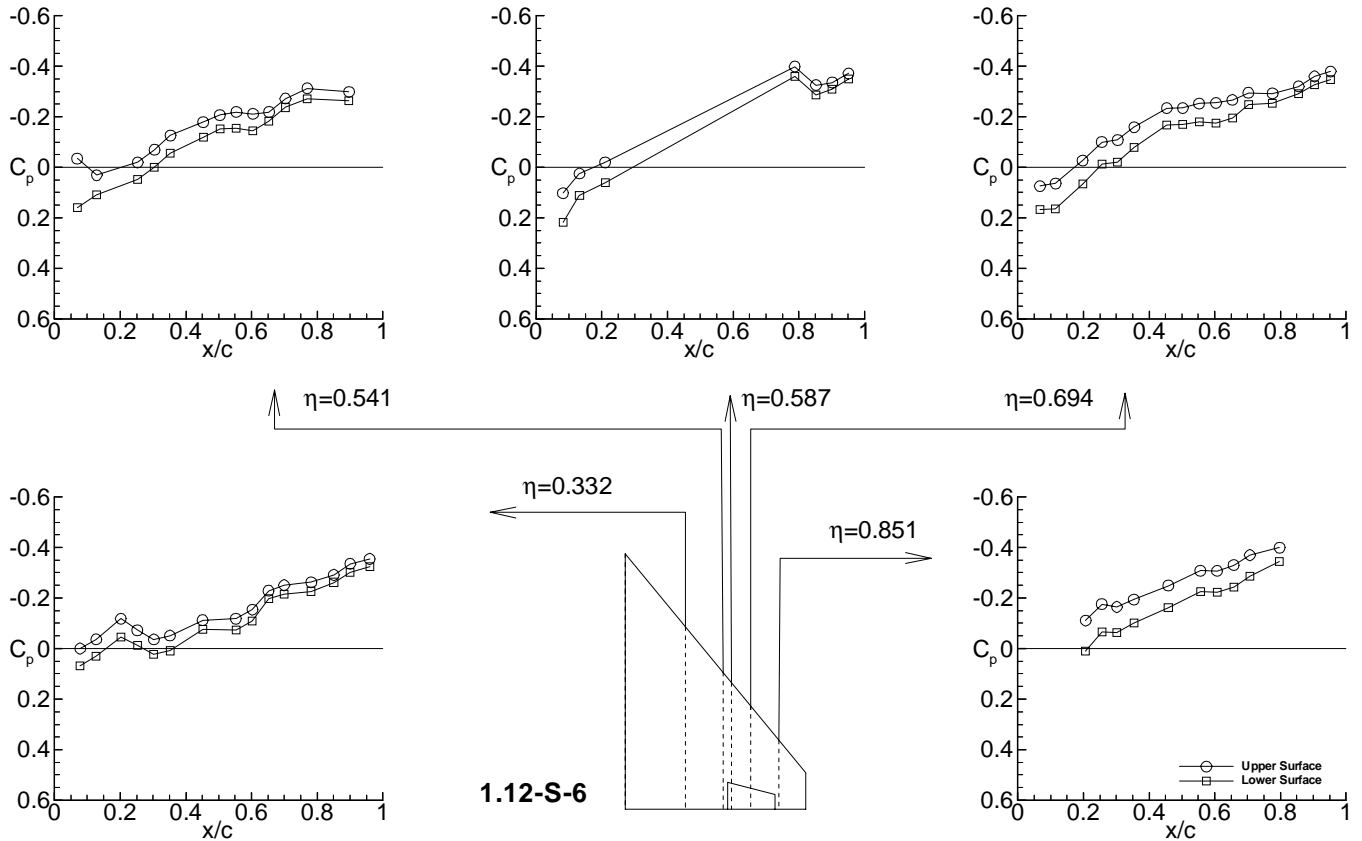

(k) Test case 9E11 (point 1.12-S-6)
Figure 5. Continued.

.40-S-11

MACH	α psf	To deg R	H psf	ALPHAo deg	THETA deg	DELTA deg	RN
0.404	78.4	525.7	926.7	3.04	0.00	0.00	9.25 *10**6

y/s= 0.332			y/s= 0.541			y/s= 0.587			y/s= 0.694			y/s= 0.851		
x/c	Cpu	Cpl	x/c	Cpu	Cpl	x/c	Cpu	Cpl	x/c	Cpu	Cpl	x/c	Cpu	Cpl
.0778	-.1330	0.1201	.0687	-.1980	0.1449	.0818	-.2427	0.1639	.0675	-.4058	0.1537	.2070	-.2425	-.0150
.1264	-.1637	0.0606	.1282	-.1752	0.0698	.1318	-.2252	0.0828	.1151	-.2339	0.1191	.2559	-.2617	-.0385
.2020	-.1821	0.0061	.2529	-.2119	-.0209	.2099	-.2341	0.0054	.1980	-.2561	0.0098	.3016	-.2644	-.0584
.2523	-.1908	-.0217	.3041	-.2460	-.0712	.7875	-.1256	-.0937	.2559	-.2722	-.0399	.3537	-.2515	-.0719
.3023	-.2078	-.0533	.3531	-.2346	-.0795	.8522	-.0741	-.0409	.3041	-.2466	-.0451	.4583	-.2868	-.1414
.3519	-.2038	-.0627	.4530	-.2324	-.1106	.9017	-.0237	-.0007	.3545	-.2619	-.0781	.5562	-.2456	-.1415
.4510	-.2314	-.1169	.5036	-.2336	-.1235	.9514	0.0247	0.0374	.4537	-.2811	-.1296	.6074	-.2167	-.1313
.5523	-.1983	-.1083	.5534	-.2147	-.1192				.5025	-.2540	-.1255	.6577	-.2099	-.1393
.6025	-.2080	-.1276	.6040	-.2182	-.1347				.5527	-.2405	-.1278	.7071	-.1801	-.1271
.6515	-.2208	-.1529	.6528	-.1949	-.1254				.6038	-.2239	-.1281	.7975	-.1143	-.0816
.6991	-.1976	-.1364	.7030	-.1733	-.1143				.6538	-.2151	-.1354			
.7813	-.1411	-.1009	.7694	-.1272	-.0861				.7025	-.1971	-.1357			
.8505	-.0848	-.0559	.8967	-.0128	0.0073				.7754	-.1091	-.0651			
.9001	-.0530	-.0327							.8553	-.0682	-.0436			
.9596	0.0169	0.0326							.9037	-.0283	-.0145			
									.9526	0.0365	0.0413			

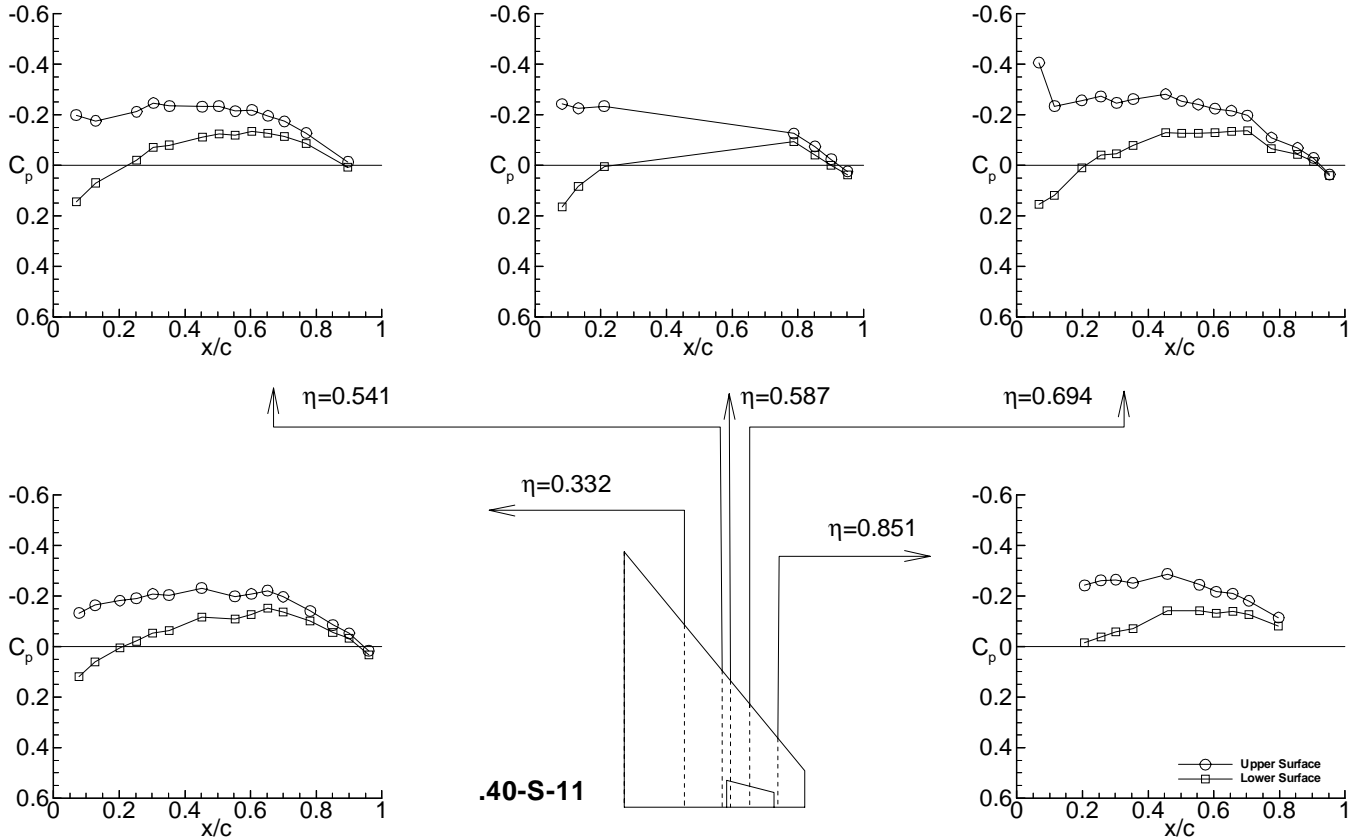

(1) Test case 9E12 (point .40-S-11)
Figure 5. Continued

.40-S-15

MACH	α	To	H	ALPHAo	THETA	DELTA	RN
	psf	deg R	psf	deg	deg	deg	
0.403	78.3	527.8	932.6	5.04	0.00	0.00	9.22 *10**6

y/s= 0.332			y/s= 0.541			y/s= 0.587			y/s= 0.694			y/s= 0.851		
x/c	Cpu	Cpl	x/c	Cpu	Cpl	x/c	Cpu	Cpl	x/c	Cpu	Cpl	x/c	Cpu	Cpl
.0778	-.6229	0.1941	.0687	-.7877	0.2235	.0818	-.7238	0.2412	.0675	-.8612	0.2418	.2070	-.8880	0.0579
.1264	-.2071	0.1290	.1282	-.5636	0.1459	.1318	-.6417	0.1576	.1151	-.8373	0.1997	.2559	-.8129	0.0288
.2020	-.2202	0.0656	.2529	-.3000	0.0395	.2099	-.4225	0.0722	.1980	-.5840	0.0835	.3016	-.7029	0.0038
.2523	-.2370	0.0324	.3041	-.3036	-.0155	.7875	-.1356	-.0836	.2559	-.4013	0.0269	.3537	-.5700	-.0165
.3023	-.2530	-.0025	.3531	-.2881	-.0279	.8522	-.0805	-.0303	.3041	-.2984	0.0170	.4583	-.3340	-.0959
.3519	-.2492	-.0170	.4530	-.2741	-.0672	.9017	-.0297	0.0046	.3545	-.2779	-.0204	.5562	-.2269	-.1080
.4510	-.2700	-.0770	.5036	-.2725	-.0860	.9514	0.0215	0.0356	.4537	-.2826	-.0820	.6074	-.1893	-.1044
.5523	-.2317	-.0766	.5534	-.2512	-.0867				.5025	-.2613	-.0837	.6577	-.1703	-.1182
.6025	-.2370	-.0999	.6040	-.2500	-.1053				.5527	-.2500	-.0909	.7071	-.1469	-.1126
.6515	-.2448	-.1277	.6528	-.2220	-.0987				.6038	-.2319	-.0962	.7975	-.0969	-.0807
.6991	-.2181	-.1158	.7030	-.1965	-.0928				.6538	-.2225	-.1083			
.7813	-.1577	-.0854	.7694	-.1462	-.0710				.7025	-.2028	-.1127			
.8505	-.0968	-.0440	.8967	-.0233	0.0141				.7754	-.1186	-.0504			
.9001	-.0620	-.0260							.8553	-.0739	-.0350			
.9596	0.0120	0.0350							.9037	-.0326	-.0100			
									.9526	0.0320	0.0412			

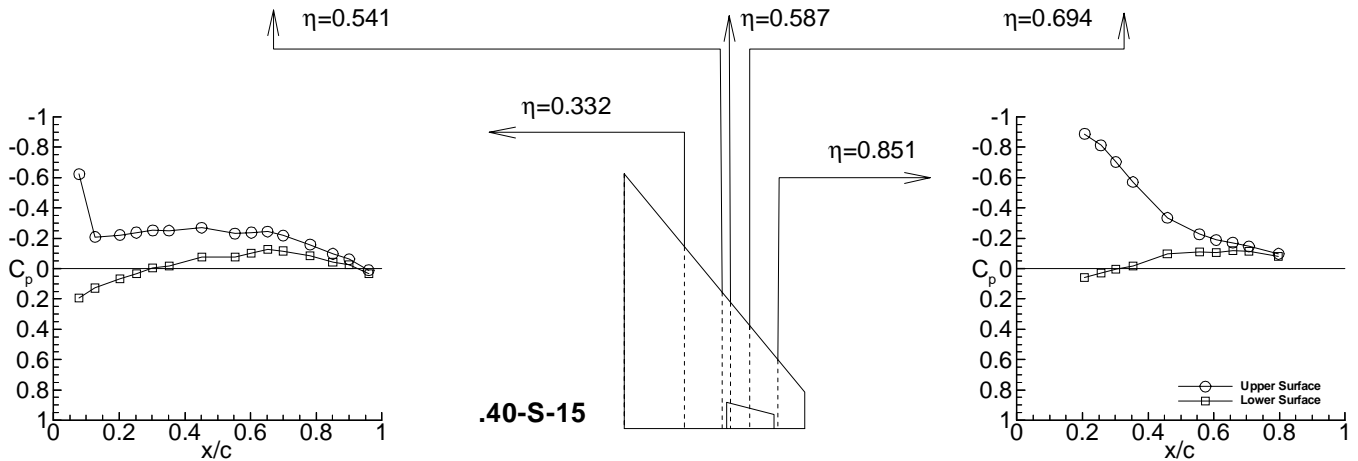
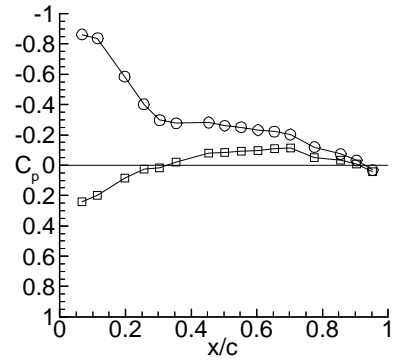
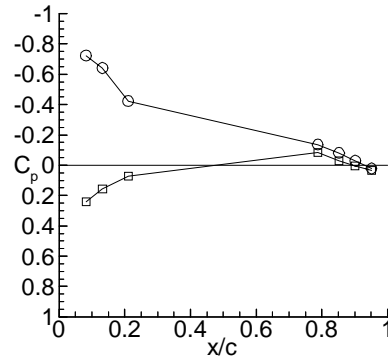
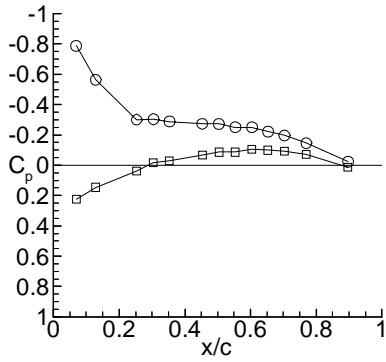

(m) Test case 9E13 (point .40-S-15)
Figure 5. Continued.

.90-S-19

MACH	q psf	T_o deg R	H psf	ALPHA o deg	THETA deg	DELTA deg	RN
0.900	192.7	566.2	656.8	2.99	0.00	0.00	9.80 *10**6

y/s= 0.332			y/s= 0.541			y/s= 0.587			y/s= 0.694			y/s= 0.851		
x/c	Cpu	Cpl	x/c	Cpu	Cpl	x/c	Cpu	Cpl	x/c	Cpu	Cpl	x/c	Cpu	Cpl
.0778	-.1157	0.1423	.0687	-.1645	0.1505	.0818	-.2628	0.1698	.0675	-.5186	0.1336	.2070	-.3539	-.0787
.1264	-.1554	0.0821	.1282	-.2208	0.0627	.1318	-.2753	0.0787	.1151	-.2509	0.0946	.2559	-.4939	-.1115
.2020	-.1855	0.0220	.2529	-.2777	-.0439	.2099	-.2953	-.0184	.1980	-.2818	-.0278	.3016	-.4585	-.1278
.2523	-.2151	-.0180	.3041	-.3338	-.1155	.7875	-.1166	-.1504	.2559	-.3603	-.0963	.3537	-.4892	-.1529
.3023	-.2600	-.0646	.3531	-.3540	-.1379	.8522	-.0482	-.0777	.3041	-.3595	-.1104	.4583	-.5373	-.2710
.3519	-.2473	-.0771	.4530	-.4013	-.1947	.9017	0.0294	0.0102	.3545	-.4215	-.1536	.5562	-.5970	-.3253
.4510	-.3274	-.1689	.5036	-.4163	-.2287	.9514	0.1018	0.0841	.4537	-.4990	-.2439	.6074	-.4813	-.3099
.5523	-.3194	-.1779	.5534	-.4285	-.2400				.5025	-.4770	-.2550	.6577	-.2045	-.2969
.6025	-.3763	-.2312	.6040	-.4527	-.2715				.5527	-.4818	-.2593	.7071	-.1470	-.2374
.6515	-.4609	-.3048	.6528	-.4805	-.2780				.6038	-.5096	-.2809	.7975	-.0713	-.1076
.6991	-.4401	-.2752	.7030	-.4824	-.2648				.6538	-.5493	-.2950			
.7813	-.2453	-.2350	.7694	-.1611	-.1764				.7025	-.4004	-.3011			
.8505	-.0906	-.1110	.8967	0.0303	0.0067				.7754	-.0780	-.1086			
.9001	-.0212	-.0450							.8553	-.0309	-.0730			
.9596	0.0861	0.0732							.9037	0.0269	-.0031			
									.9526	0.1046	0.0831			

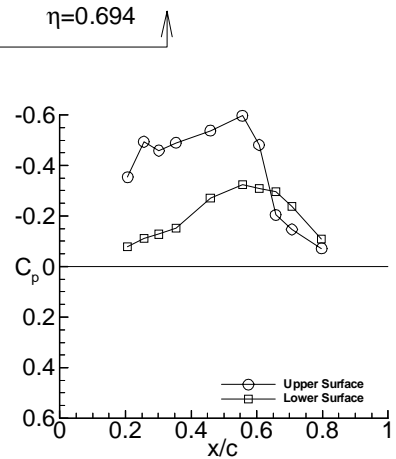
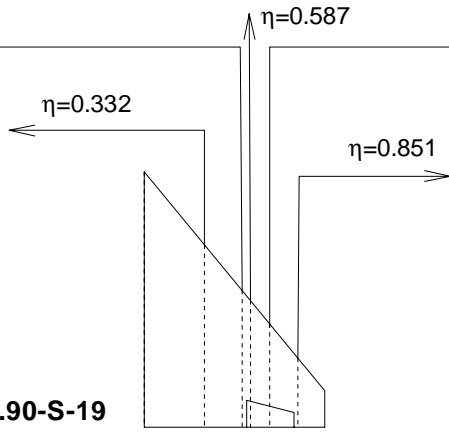
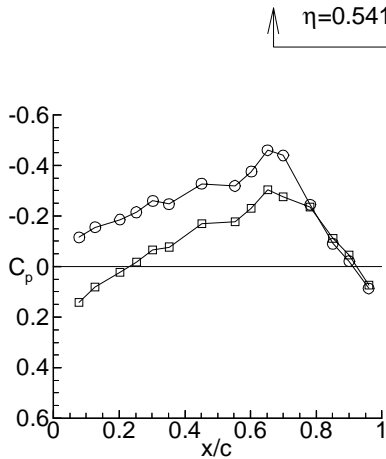
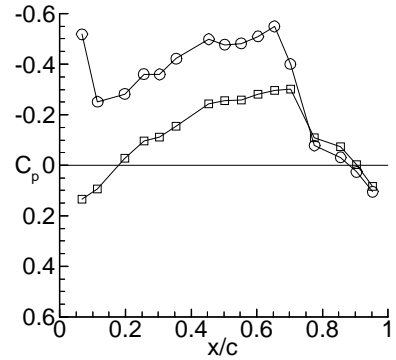
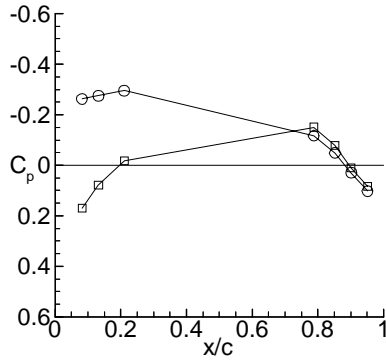
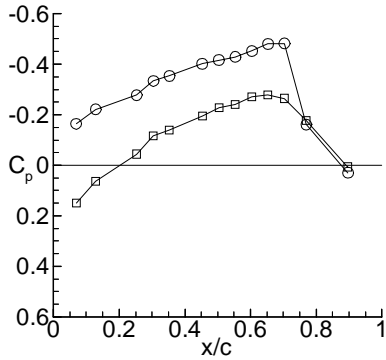

(n) Test case 9E14 (point .90-S-19)
Figure 5. Continued.

.90-S-38

MACH	q psf	T_o deg R	H psf	ALPHA o deg	THETA deg	DELTA deg	RN
0.901	193.1	556.7	657.2	4.24	0.00	0.00	10.08 *10**6

y/s= 0.332			y/s= 0.541			y/s= 0.587			y/s= 0.694			y/s= 0.851		
x/c	Cpu	Cpl	x/c	Cpu	Cpl	x/c	Cpu	Cpl	x/c	Cpu	Cpl	x/c	Cpu	Cpl
.0778	-.2488	0.1874	.0687	-.7164	0.2032	.0818	-.5010	0.2256	.0675	-.8835	0.1957	.2070	-.7944	-.0191
.1264	-.1859	0.1249	.1282	-.4673	0.1180	.1318	-.4816	0.1360	.1151	-.7772	0.1535	.2559	-.6952	-.0549
.2020	-.2332	0.0600	.2529	-.3117	0.0005	.2099	-.4176	0.0307	.1980	-.4440	0.0236	.3016	-.6302	-.0763
.2523	-.2628	0.0196	.3041	-.3755	-.0715	.7875	-.1415	-.1461	.2559	-.4078	-.0452	.3537	-.5967	-.1015
.3023	-.3109	-.0271	.3531	-.3983	-.0941	.8522	-.0469	-.0788	.3041	-.3984	-.0602	.4583	-.6162	-.2219
.3519	-.2946	-.0427	.4530	-.4457	-.1532	.9017	0.0297	0.0072	.3545	-.4528	-.1057	.5562	-.5202	-.2784
.4510	-.3584	-.1351	.5036	-.4658	-.1904	.9514	0.0898	0.0833	.4537	-.5477	-.1936	.6074	-.3307	-.2712
.5523	-.3585	-.1487	.5534	-.4770	-.2013				.5025	-.5368	-.2058	.6577	-.2292	-.2771
.6025	-.4130	-.1979	.6040	-.5036	-.2356				.5527	-.5385	-.2174	.7071	-.1834	-.2428
.6515	-.5011	-.2625	.6528	-.5279	-.2427				.6038	-.5585	-.2338	.7975	-.1012	-.1259
.6991	-.4896	-.2421	.7030	-.5100	-.2365				.6538	-.5786	-.2590			
.7813	-.2364	-.2088	.7694	-.1617	-.1671				.7025	-.3105	-.2689			
.8505	-.0880	-.1107	.8967	0.0273	0.0063				.7754	-.0813	-.1108			
.9001	-.0214	-.0524							.8553	-.0334	-.0764			
.9596	0.0831	0.0663							.9037	0.0249	-.0085			
									.9526	0.0999	0.0784			

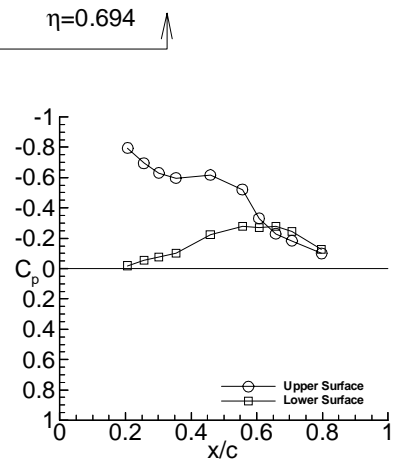
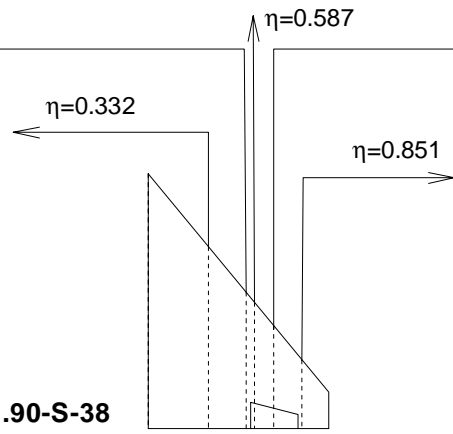
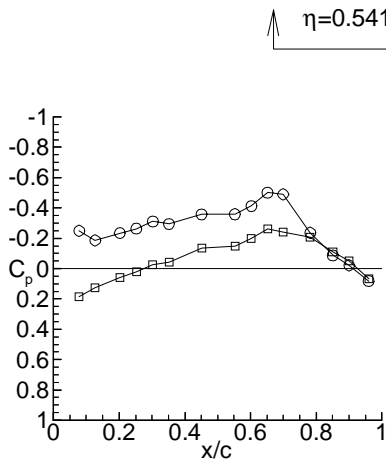
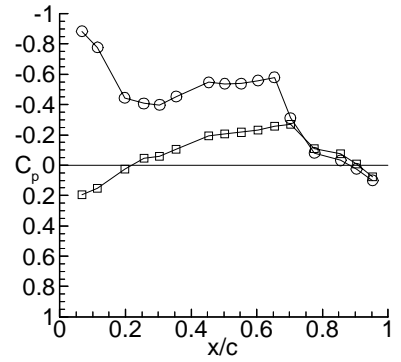
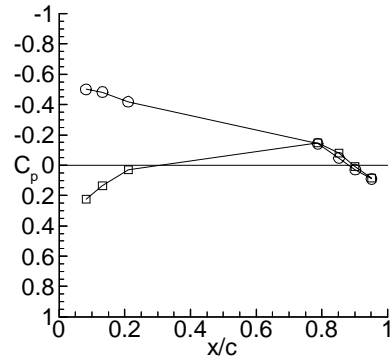
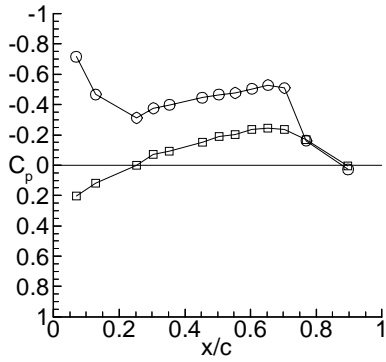

(o) Test case 9E15 (point .90-S-38)
Figure 5. Continued.

.40-S-3

MACH	q psf	To deg R	H psf	ALPHAO deg	THETA deg	DELTA deg	RN
0.406	85.3	548.0	1004.7	0.05	0.00	4.00	9.50 *10**6

y/s= 0.332			y/s= 0.541			y/s= 0.587			y/s= 0.694			y/s= 0.851		
x/c	Cpu	Cpl	x/c	Cpu	Cpl	x/c	Cpu	Cpl	x/c	Cpu	Cpl	x/c	Cpu	Cpl
.0778	-.0126	-.0045	.0687	-.0200	-.0114	.0818	-.0025	0.0099	.0675	-.0475	-.0277	.2070	-.1753	-.1409
.1264	-.0527	-.0461	.1282	-.0704	-.0592	.1318	-.0600	-.0464	.1151	-.0434	-.0257	.2559	-.1839	-.1466
.2020	-.0874	-.0809	.2529	-.1226	-.1097	.2099	-.1104	-.0958	.1980	-.1303	-.1106	.3016	-.1906	-.1507
.2523	-.1078	-.0999	.3041	-.1656	-.1501	.7875	-.1811	-.0394	.2559	-.1632	-.1414	.3537	-.1895	-.1479
.3023	-.1314	-.1236	.3531	-.1653	-.1489	.8522	-.1104	0.0009	.3041	-.1581	-.1335	.4583	-.2399	-.1904
.3519	-.1338	-.1251	.4530	-.1827	-.1615	.9017	-.0384	0.0132	.3545	-.1810	-.1529	.5562	-.2229	-.1656
.4510	-.1760	-.1658	.5036	-.1895	-.1659	.9514	0.0280	0.0364	.4537	-.2216	-.1843	.6074	-.2059	-.1424
.5523	-.1566	-.1444	.5534	-.1830	-.1559				.5025	-.2113	-.1680	.6577	-.2090	-.1381
.6025	-.1722	-.1583	.6040	-.1919	-.1598				.5527	-.2087	-.1557	.7071	-.1919	-.1159
.6515	-.1917	-.1762	.6528	-.1790	-.1410				.6038	-.2094	-.1438	.7975	-.1334	-.0538
.6991	-.1718	-.1555	.7030	-.1659	-.1206				.6538	-.2161	-.1307			
.7813	-.1286	-.1116	.7694	-.1377	-.0759				.7025	-.2237	-.1083			
.8505	-.0754	-.0614	.8967	-.0276	0.0108				.7754	-.1841	0.0185			
.9001	-.0454	-.0338							.8553	-.1421	0.0257			
.9596	0.0269	0.0345							.9037	-.0592	0.0200			
									.9526	0.0277	0.0550			

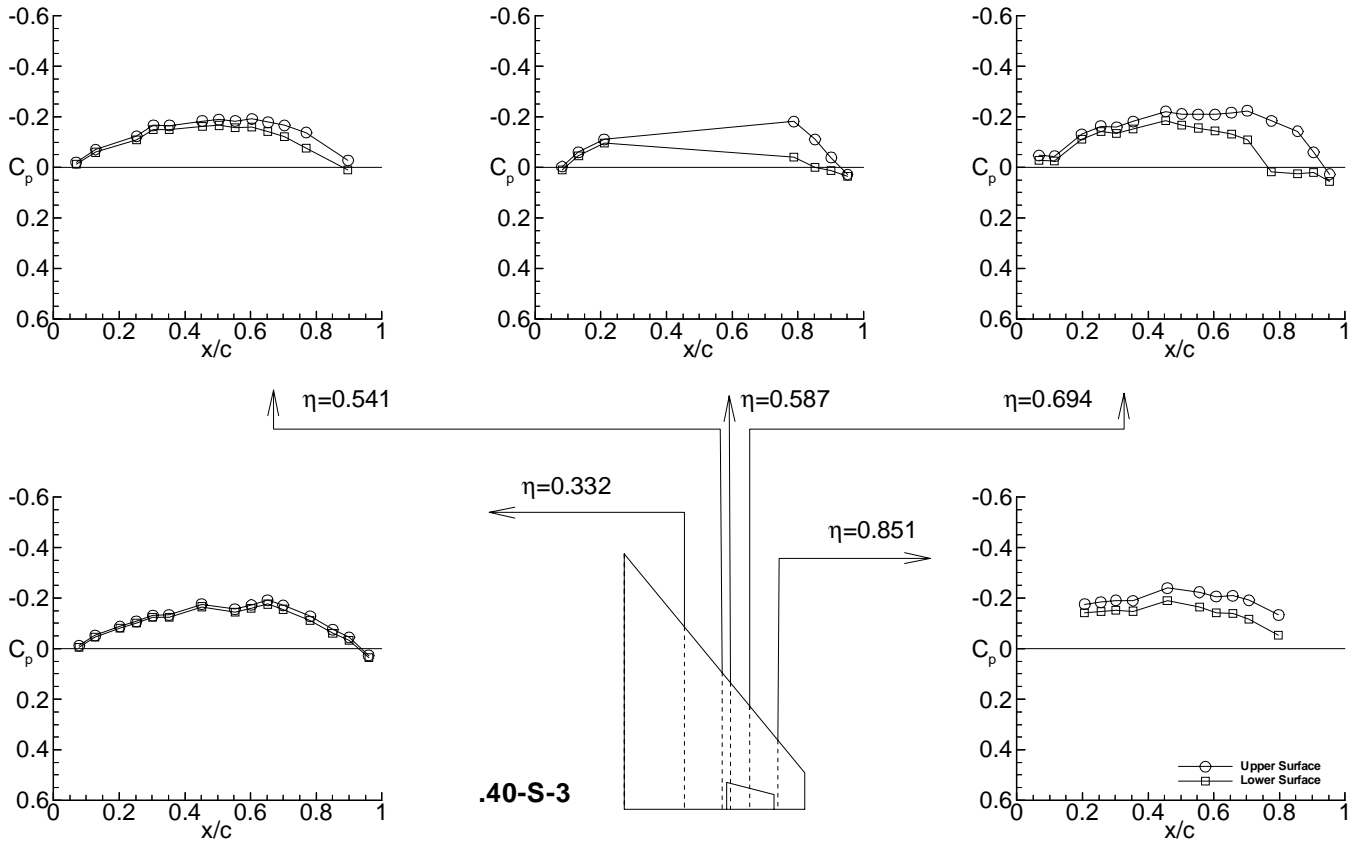

(p) Test case 9E16 (point .40-S-3)
Figure 5. Continued.

.90-S-2

MACH	α psf	To deg R	H psf	ALPHAo deg	THETA deg	DELTA deg	RN
0.898	190.8	562.9	651.9	0.05	0.00	2.00	9.83 *10**6

y/s= 0.332			y/s= 0.541			y/s= 0.587			y/s= 0.694			y/s= 0.851		
x/c	Cpu	Cpl	x/c	Cpu	Cpl	x/c	Cpu	Cpl	x/c	Cpu	Cpl	x/c	Cpu	Cpl
.0778	0.0205	0.0190	.0687	0.0050	0.0023	.0818	0.0196	0.0173	.0675	-.0533	-.0547	.2070	-.2722	-.2700
.1264	-.0332	-.0337	.1282	-.0756	-.0792	.1318	-.0582	-.0609	.1151	-.0577	-.0582	.2559	-.3223	-.3174
.2020	-.0803	-.0798	.2529	-.1556	-.1551	.2099	-.1464	-.1480	.1980	-.1759	-.1758	.3016	-.2916	-.2862
.2523	-.1133	-.1126	.3041	-.2259	-.2257	.7875	-.2181	-.1122	.2559	-.2409	-.2403	.3537	-.3116	-.3047
.3023	-.1578	-.1570	.3531	-.2473	-.2469	.8522	-.1242	-.0443	.3041	-.2497	-.2483	.4583	-.4152	-.3996
.3519	-.1625	-.1622	.4530	-.2891	-.2879	.9017	-.0001	0.0165	.3545	-.2912	-.2890	.5562	-.4573	-.4091
.4510	-.2488	-.2473	.5036	-.3260	-.3228	.9514	0.0984	0.0781	.4537	-.3805	-.3728	.6074	-.4208	-.3481
.5523	-.2436	-.2425	.5534	-.3242	-.3185				.5025	-.3662	-.3582	.6577	-.3918	-.2780
.6025	-.3003	-.2989	.6040	-.3555	-.3476				.5527	-.3793	-.3654	.7071	-.3137	-.1961
.6515	-.3712	-.3638	.6528	-.3656	-.3486				.6038	-.4018	-.3775	.7975	-.1220	-.0721
.6991	-.3334	-.3248	.7030	-.3501	-.3167				.6538	-.4116	-.3558			
.7813	-.2615	-.2356	.7694	-.2340	-.1565				.7025	-.4064	-.2915			
.8505	-.1296	-.1065	.8967	-.0035	0.0180				.7754	-.2179	-.0513			
.9001	-.0497	-.0348							.8553	-.1142	-.0161			
.9596	0.0680	0.0777							.9037	0.0033	0.0206			
									.9526	0.1072	0.0915			

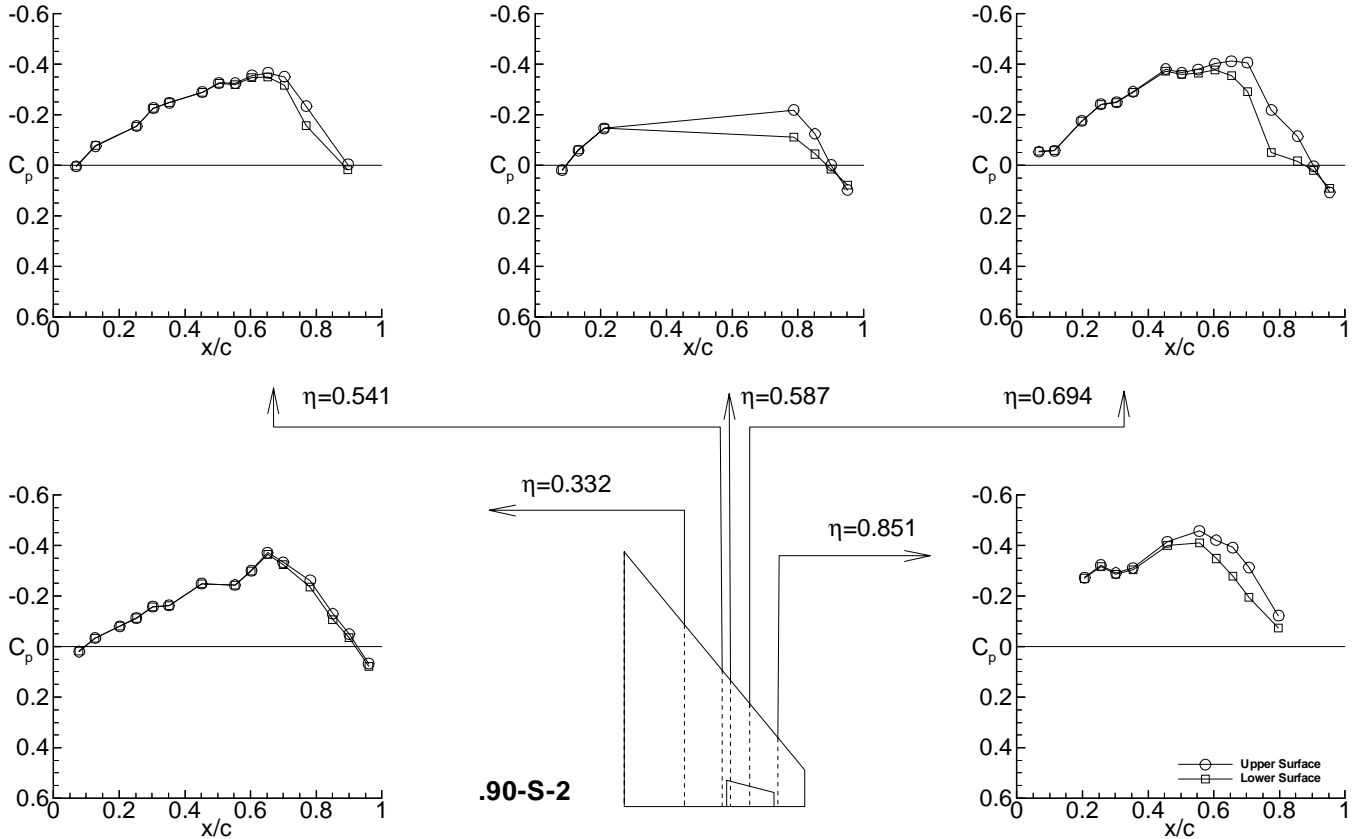

(q) Test case 9E17 (point .90-S-2)
Figure 5. Continued.

.90-S-3

MACH	q psf	T_o deg R	H psf	ALPHA o deg	THETA deg	DELTA deg	RN
0.896	190.4	563.0	652.0	0.05	0.00	4.00	9.82 *10**6

y/s= 0.332			y/s= 0.541			y/s= 0.587			y/s= 0.694			y/s= 0.851		
x/c	Cpu	Cpl	x/c	Cpu	Cpl	x/c	Cpu	Cpl	x/c	Cpu	Cpl	x/c	Cpu	Cpl
.0778	0.0181	0.0188	.0687	0.0003	-.0046	.0818	0.0163	0.0232	.0675	-.0536	-.0542	.2070	-.2721	-.2699
.1264	-.0328	-.0323	.1282	-.0785	-.0795	.1318	-.0604	-.0603	.1151	-.0582	-.0572	.2559	-.3195	-.3215
.2020	-.0803	-.0794	.2529	-.1551	-.1560	.2099	-.1474	-.1489	.1980	-.1755	-.1751	.3016	-.2902	-.2894
.2523	-.1131	-.1118	.3041	-.2256	-.2263	.7875	-.2856	-.0557	.2559	-.2391	-.2411	.3537	-.3124	-.3027
.3023	-.1574	-.1567	.3531	-.2455	-.2512	.8522	-.1536	0.0096	.3041	-.2485	-.2484	.4583	-.4186	-.3960
.3519	-.1630	-.1620	.4530	-.2885	-.2862	.9017	-.0170	0.0369	.3545	-.2897	-.2901	.5562	-.4691	-.3958
.4510	-.2483	-.2471	.5036	-.3246	-.3243	.9514	0.0977	0.0783	.4537	-.3766	-.3762	.6074	-.4406	-.3116
.5523	-.2435	-.2416	.5534	-.3226	-.3218				.5025	-.3661	-.3569	.6577	-.4354	-.2178
.6025	-.2996	-.2968	.6040	-.3569	-.3480				.5527	-.3786	-.3629	.7071	-.3767	-.1603
.6515	-.3682	-.3604	.6528	-.3684	-.3487				.6038	-.4043	-.3680	.7975	-.1620	-.0444
.6991	-.3353	-.3189	.7030	-.3595	-.3040				.6538	-.4204	-.3308			
.7813	-.2704	-.2203	.7694	-.2764	-.1234				.7025	-.4298	-.2268			
.8505	-.1297	-.0933	.8967	-.0272	0.0317				.7754	-.3100	0.0159			
.9001	-.0568	-.0306							.8553	-.1531	0.0401			
.9596	0.0729	0.0788							.9037	0.0014	0.0375			
									.9526	0.1096	0.0832			

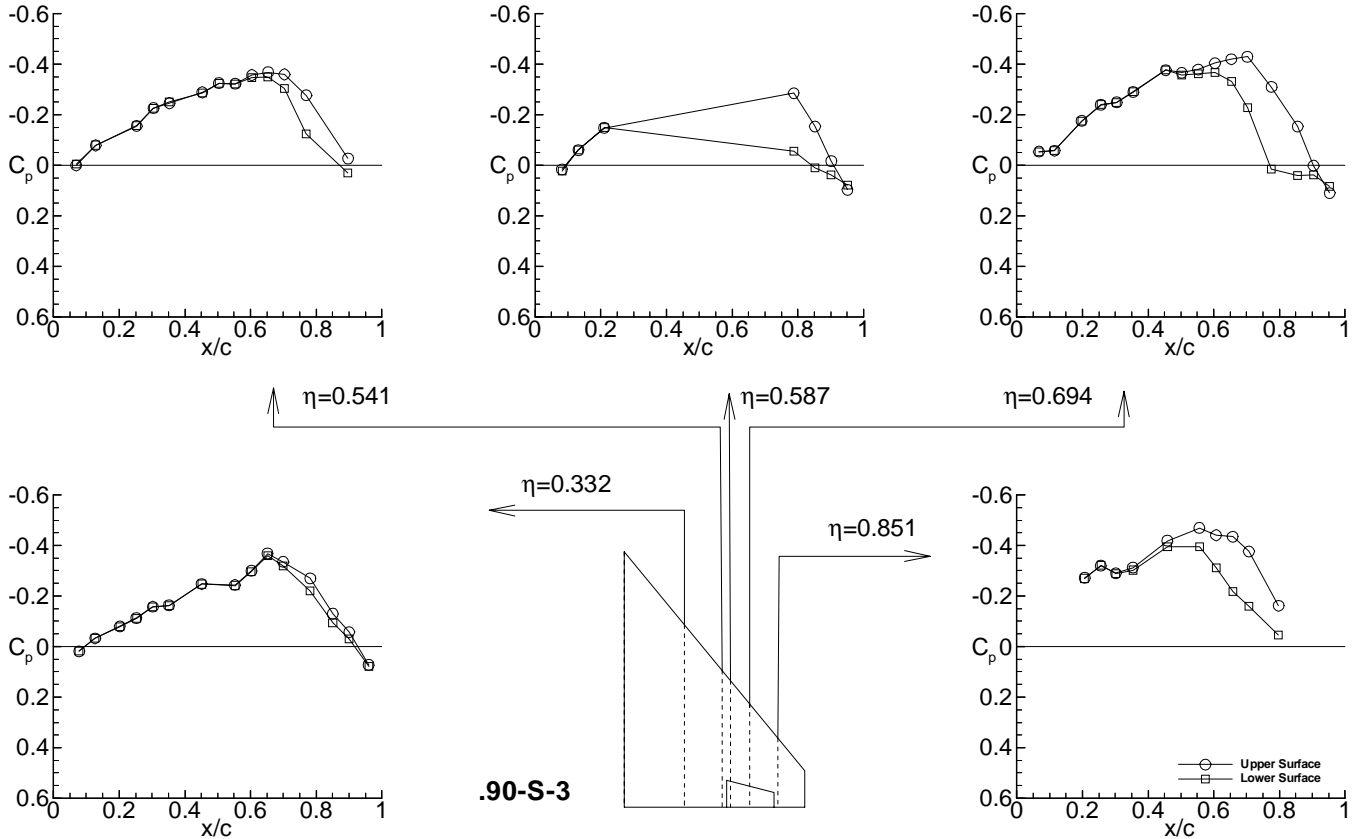

(r) Test case 9E18 (point .90-S-3)
Figure 5. Continued.

.94-S-3

MACH	q psf	T_o deg R	H psf	ALPHA o deg	THETA deg	DELTA deg	RN
0.944	203.7	562.1	658.9	0.05	0.00	4.00	10.09 *10**6

y/s= 0.332			y/s= 0.541			y/s= 0.587			y/s= 0.694			y/s= 0.851		
x/c	Cpu	Cpl	x/c	Cpu	Cpl	x/c	Cpu	Cpl	x/c	Cpu	Cpl	x/c	Cpu	Cpl
.0778	0.0310	0.0331	.0687	0.0157	0.0140	.0818	0.0302	0.0323	.0675	-.0605	-.0621	.2070	-.2332	-.2336
.1264	-.0197	-.0172	.1282	-.0733	-.0730	.1318	-.0518	-.0509	.1151	-.0424	-.0422	.2559	-.3287	-.3269
.2020	-.0647	-.0627	.2529	-.1378	-.1366	.2099	-.1413	-.1401	.1980	-.1421	-.1393	.3016	-.3074	-.3066
.2523	-.0973	-.0953	.3041	-.2043	-.2038	.7875	-.5485	-.4476	.2559	-.2252	-.2236	.3537	-.3444	-.3427
.3023	-.1433	-.1422	.3531	-.2379	-.2389	.8522	-.2072	-.1302	.3041	-.2327	-.2307	.4583	-.4209	-.4221
.3519	-.1404	-.1382	.4530	-.3042	-.3023	.9017	-.0433	0.0228	.3545	-.2987	-.2972	.5562	-.4709	-.4730
.4510	-.2362	-.2345	.5036	-.3202	-.3183	.9514	0.0496	0.0751	.4537	-.3827	-.3808	.6074	-.4687	-.4655
.5523	-.2463	-.2438	.5534	-.3378	-.3366				.5025	-.3784	-.3771	.6577	-.5225	-.5189
.6025	-.3075	-.3068	.6040	-.3612	-.3599				.5527	-.3788	-.3801	.7071	-.5978	-.5935
.6515	-.3960	-.3928	.6528	-.3967	-.3945				.6038	-.4126	-.4106	.7975	-.4471	-.3809
.6991	-.3989	-.3958	.7030	-.4425	-.4404				.6538	-.4688	-.4655			
.7813	-.4072	-.4058	.7694	-.4596	-.4585				.7025	-.5225	-.5189			
.8505	-.3228	-.3025	.8967	-.0239	0.0084				.7754	-.5225	-.4462			
.9001	-.0295	-.0132							.8553	-.1409	-.0573			
.9596	0.1056	0.1086							.9037	-.0250	0.0131			
									.9526	0.0422	0.0448			

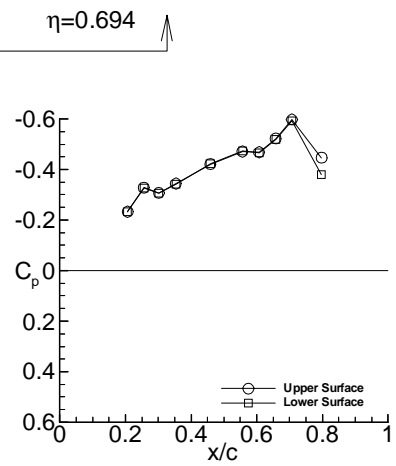
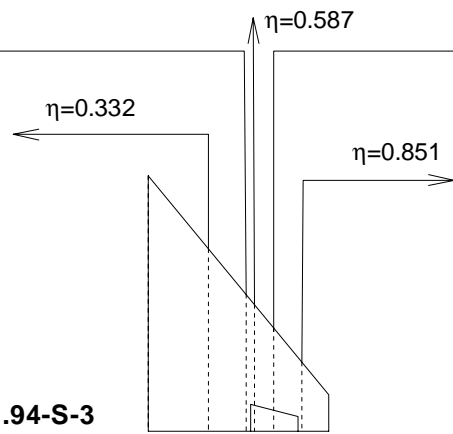
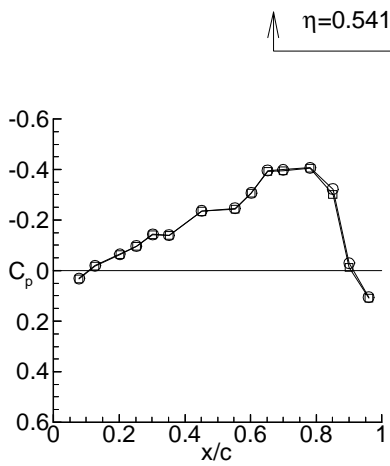
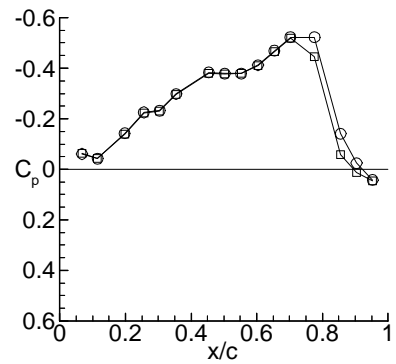
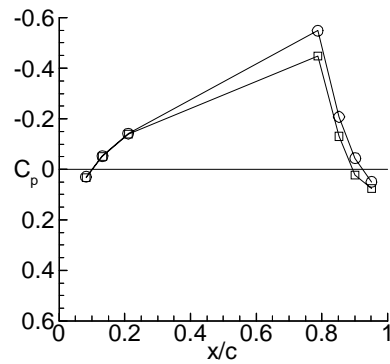
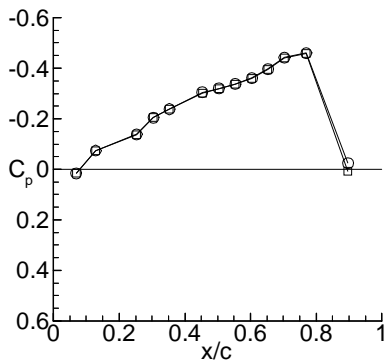

(s) Test case 9E19 (point .94-S-3)
Figure 5. Continued.

1.12-S-3

MACH	q		To	H	$ALPHA_0$	$THETA$	$DELTA$	RN
	psf	deg R	psf	deg	deg	deg	deg	
1.120	231.1	575.9	642.5	0.00	0.00	4.00	9.61	$\times 10^{**6}$

$y/s = 0.332$			$y/s = 0.541$			$y/s = 0.587$			$y/s = 0.694$			$y/s = 0.851$		
x/c	Cpu	Cpl	x/c	Cpu	Cpl	x/c	Cpu	Cpl	x/c	Cpu	Cpl	x/c	Cpu	Cpl
.0778	0.0354	0.0345	.0687	0.0725	0.0650	.0818	0.1785	0.1755	.0675	0.1158	0.1098	.2070	-.0403	-.0352
.1264	-.0008	-.0021	.1282	0.0824	0.0791	.1318	0.0692	0.0667	.1151	0.1281	0.1178	.2559	-.1126	-.1129
.2020	-.0871	-.0832	.2529	0.0246	0.0053	.2099	0.0286	0.0111	.1980	0.0280	0.0108	.3016	-.1083	-.1085
.2523	-.0452	-.0442	.3041	-.0190	-.0405	.7875	-.3811	-.3729	.2559	-.0456	-.0622	.3537	-.1484	-.1463
.3023	-.0008	-.0113	.3531	-.0799	-.0827	.8522	-.3770	-.2247	.3041	-.0536	-.0542	.4583	-.2091	-.2074
.3519	0.0059	-.0330	.4530	-.1520	-.1488	.9017	-.3737	-.2585	.3545	-.1125	-.1111	.5562	-.2679	-.2654
.4510	-.0994	-.0940	.5036	-.1846	-.1772	.9514	-.4071	-.3057	.4537	-.2015	-.1978	.6074	-.2680	-.2631
.5523	-.1042	-.0979	.5534	-.1931	-.1876				.5025	-.2045	-.1999	.6577	-.2912	-.2864
.6025	-.1382	-.1317	.6040	-.1808	-.1786				.5527	-.2184	-.2152	.7071	-.3390	-.3340
.6515	-.2160	-.2145	.6528	-.2011	-.1995				.6038	-.2160	-.2114	.7975	-.3773	-.3708
.6991	-.2361	-.2347	.7030	-.2566	-.2555				.6538	-.2388	-.2307			
.7813	-.2451	-.2444	.7694	-.2923	-.2914				.7025	-.2696	-.2673			
.8505	-.2791	-.2783	.8967	-.3103	-.2550				.7754	-.2767	-.2741			
.9001	-.3205	-.3185							.8553	-.4229	-.1814			
.9596	-.3403	-.3393							.9037	-.4653	-.2208			
									.9526	-.4690	-.2541			

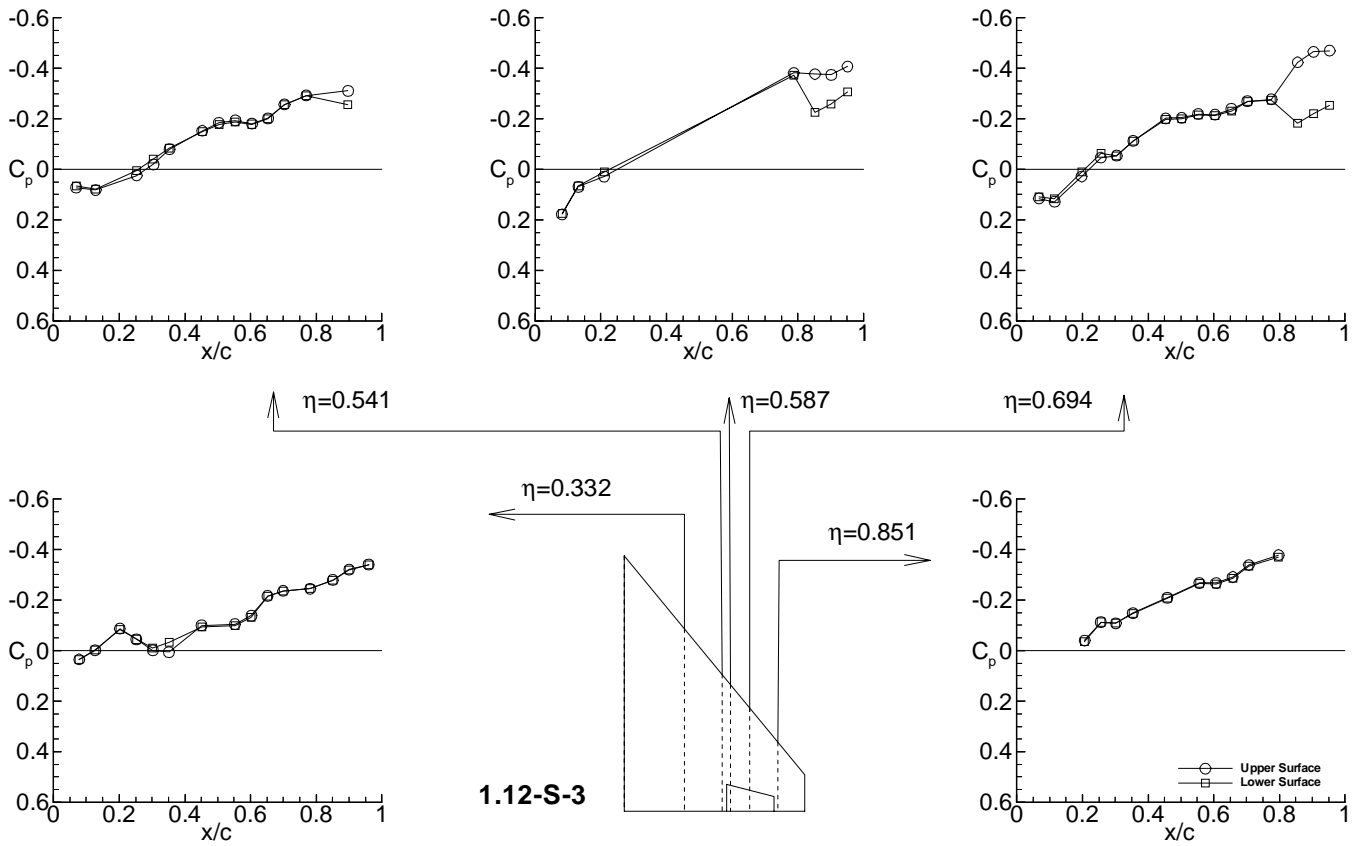

(t) Test case 9E20 (point 1.12-S-3)
Figure 5. Continued.

.90-S-21

MACH	α psf	To deg R	H psf	ALPHAo deg	THETA deg	DELTA deg	RN
0.901	193.1	566.3	657.4	2.99	0.00	4.00	9.81 *10**6

y/s= 0.332			y/s= 0.541			y/s= 0.587			y/s= 0.694			y/s= 0.851		
x/c	Cpu	Cpl	x/c	Cpu	Cpl	x/c	Cpu	Cpl	x/c	Cpu	Cpl	x/c	Cpu	Cpl
.0778	-.1171	0.1397	.0687	-.1593	0.1493	.0818	-.2644	0.1730	.0675	-.5380	0.1363	.2070	-.3578	-.0725
.1264	-.1573	0.0788	.1282	-.2216	0.0619	.1318	-.2754	0.0787	.1151	-.2590	0.0974	.2559	-.4908	-.1053
.2020	-.1864	0.0178	.2529	-.2793	-.0431	.2099	-.2964	-.0202	.1980	-.2800	-.0265	.3016	-.4524	-.1205
.2523	-.2168	-.0211	.3041	-.3350	-.1150	.7875	-.2260	-.0507	.2559	-.3623	-.0915	.3537	-.4853	-.1413
.3023	-.2598	-.0680	.3531	-.3542	-.1372	.8522	-.1168	0.0133	.3041	-.3594	-.1060	.4583	-.5359	-.2532
.3519	-.2474	-.0803	.4530	-.3992	-.1914	.9017	0.0038	0.0362	.3545	-.4193	-.1468	.5562	-.6014	-.2760
.4510	-.3311	-.1699	.5036	-.4141	-.2274	.9514	0.0972	0.0708	.4537	-.4965	-.2312	.6074	-.5687	-.2363
.5523	-.3216	-.1779	.5534	-.4298	-.2333				.5025	-.4767	-.2389	.6577	-.4035	-.2072
.6025	-.3744	-.2249	.6040	-.4518	-.2645				.5527	-.4838	-.2390	.7071	-.2165	-.1606
.6515	-.4600	-.2909	.6528	-.4829	-.2624				.6038	-.5111	-.2406	.7975	-.1324	-.0600
.6991	-.4314	-.2599	.7030	-.4985	-.2301				.6538	-.5546	-.2314			
.7813	-.2725	-.1975	.7694	-.2516	-.1164				.7025	-.5594	-.1815			
.8505	-.1107	-.0937	.8967	0.0010	0.0308				.7754	-.2049	0.0237			
.9001	-.0345	-.0385							.8553	-.1122	0.0419			
.9596	0.0794	0.0710							.9037	0.0064	0.0358			
									.9526	0.1029	0.0815			

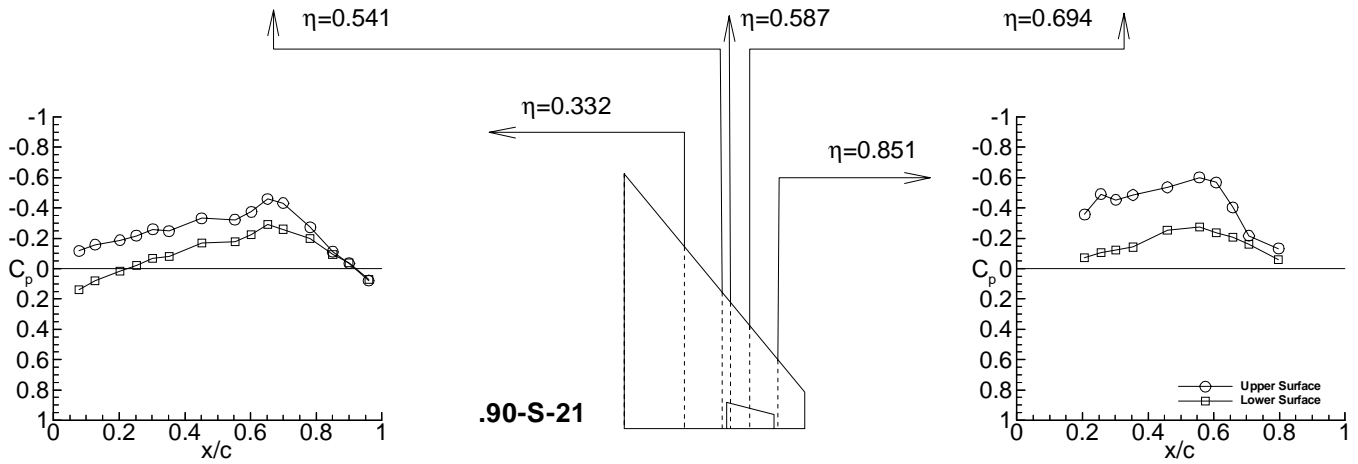
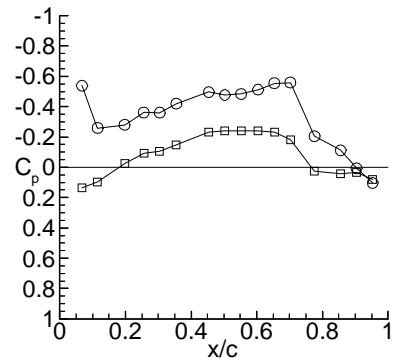
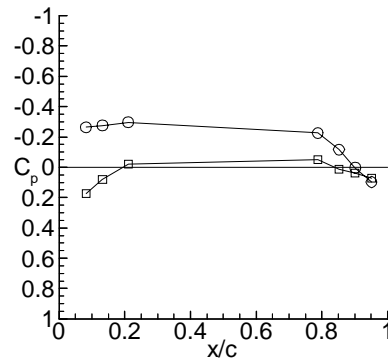
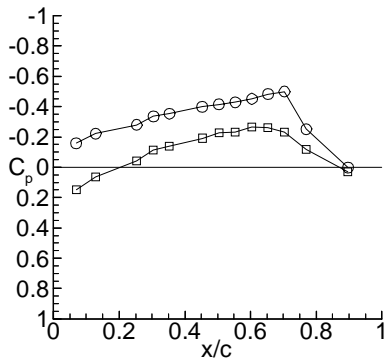

(u) Test case 9E21 (point .90-S-21)
Figure 5. Continued.

.90-S-24

MACH	q psf	T_o deg R	H psf	ALPHA $_o$ deg	THETA deg	DELTA deg	RN
0.896	192.1	566.6	657.8	2.99	0.00	-4.00	9.80 *10**6

y/s= 0.332			y/s= 0.541			y/s= 0.587			y/s= 0.694			y/s= 0.851		
x/c	Cpu	Cpl	x/c	Cpu	Cpl	x/c	Cpu	Cpl	x/c	Cpu	Cpl	x/c	Cpu	Cpl
.0778	-.1178	0.1408	.0687	-.1747	0.1528	.0818	-.2667	0.1711	.0675	-.5681	0.1361	.2070	-.3582	-.0818
.1264	-.1574	0.0793	.1282	-.2225	0.0627	.1318	-.2764	0.0773	.1151	-.2725	0.0957	.2559	-.4864	-.1185
.2020	-.1858	0.0171	.2529	-.2812	-.0437	.2099	-.2970	-.0219	.1980	-.2794	-.0291	.3016	-.4458	-.1354
.2523	-.2160	-.0221	.3041	-.3370	-.1183	.7875	-.0486	-.2910	.2559	-.3638	-.0962	.3537	-.4751	-.1617
.3023	-.2610	-.0694	.3531	-.3541	-.1406	.8522	0.0069	-.1736	.3041	-.3603	-.1120	.4583	-.5111	-.2874
.3519	-.2496	-.0822	.4530	-.3994	-.1988	.9017	0.0378	-.0215	.3545	-.4182	-.1558	.5562	-.3001	-.3495
.4510	-.3324	-.1735	.5036	-.4109	-.2391	.9514	0.0837	0.0880	.4537	-.4911	-.2486	.6074	-.1939	-.3558
.5523	-.3220	-.1840	.5534	-.4240	-.2491				.5025	-.4695	-.2621	.6577	-.1730	-.3962
.6025	-.3733	-.2357	.6040	-.4385	-.2854				.5527	-.4683	-.2692	.7071	-.1379	-.4217
.6515	-.4501	-.3110	.6528	-.4073	-.3078				.6038	-.4510	-.2954	.7975	-.0362	-.1765
.6991	-.3736	-.2940	.7030	-.2696	-.3024				.6538	-.2908	-.3231			
.7813	-.1997	-.2627	.7694	-.1137	-.2661				.7025	-.1666	-.3634			
.8505	-.0812	-.1387	.8967	0.0421	-.0274				.7754	0.0235	-.3046			
.9001	-.0187	-.0651							.8553	0.0438	-.1754			
.9596	0.0835	0.0630							.9037	0.0440	-.0042			
									.9526	0.0904	0.1034			

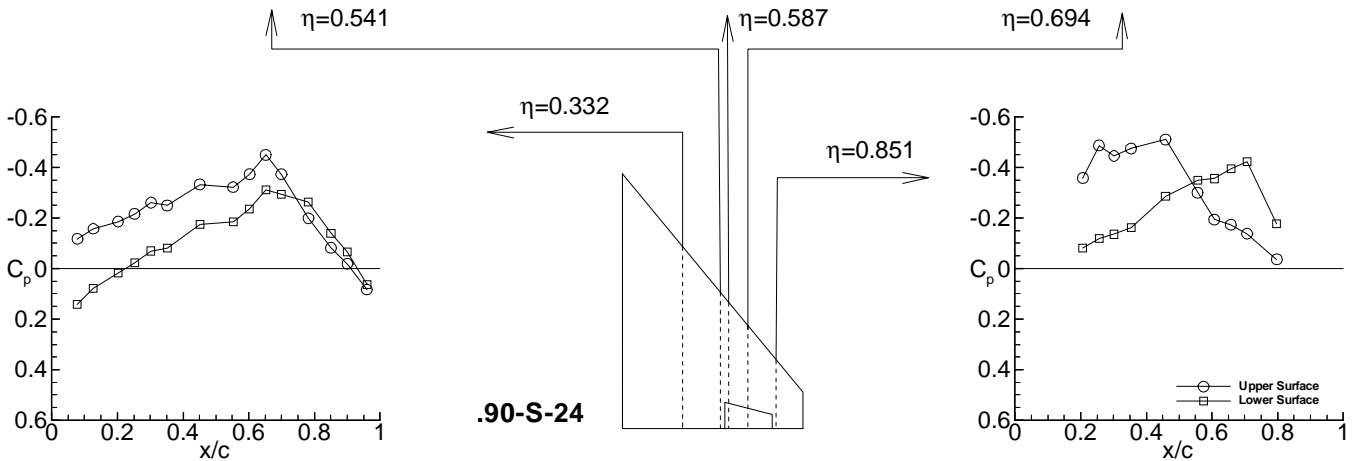
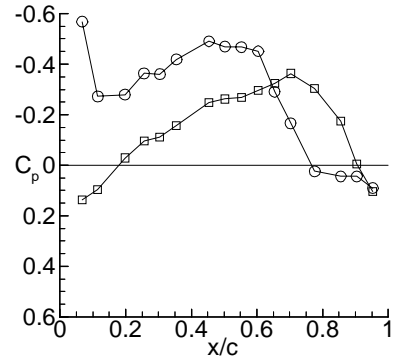
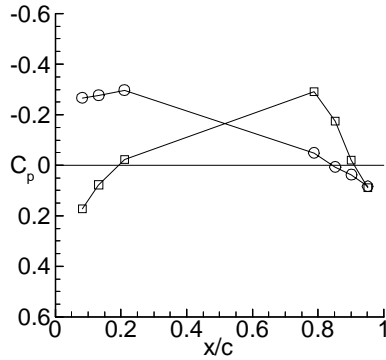
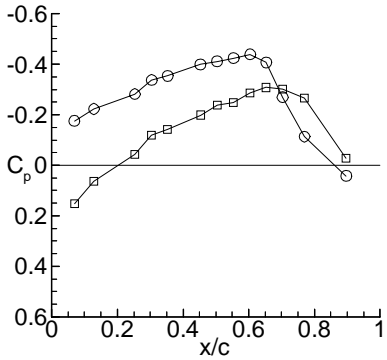

(v) Test case 9E22 (point .90-S-24)
Figure 5. Concluded.

.40-D-5

MACH	q	To	H	ALPHAo	THETA	DELTA	RN
	psf	deg R	psf	deg	deg	deg	
0.403	76.9	518.7	915.1	0.05	0.47	0.00	9.28*10**6

f = 4.00 Hz k = 0.194

y/s = 0.337				y/s = 0.546					
x/c	Upper		Lower		x/c	Upper		Lower	
	Real	Imag	Real	Imag		Real	Imag	Real	Imag
.0731	-1.0164	0.1248			.0681	0.7368	-1.7400		
.1120	-2.3645	-0.0454			.1217	-3.1206	-0.0381		
.1974	-2.0841	-0.2301			.2485	-2.1679	-0.3395		
.2478	-1.8585	-0.3411			.3004	-1.5804	-0.3620		
.2987	-1.6538	-0.4215			.3481	-1.7612	-0.4917		
.3486	-1.8719	-0.6666			.4487	-1.7069	-0.6212		
.4477	-1.1773	-0.6419			.4997	-1.0616	-0.5479		
.5506	-0.9253	-0.6551			.5500	-1.0158	-0.5561		
.6009	-0.8752	-0.7396			.6014	-0.8945	-0.5699		
.6459	-0.7016	-0.7291			.6494	-0.7760	-0.6106		
.6979	-0.4547	-0.6190			.6995	-0.6348	-0.5518		
.7805	-0.3002	-0.5995			.7747	-0.4095	-0.4678		
.8500	-0.1637	-0.4980			.8964	-0.2959	-0.4028		
.8996	-0.0484	-0.3871							
.9495	0.0681	-0.2341							

y/s = 0.590				y/s = 0.698					
x/c	Upper		Lower		x/c	Upper		Lower	
	Real	Imag	Real	Imag		Real	Imag	Real	Imag
.0767	-2.2447	3.4698			.0754	-3.0719	0.0322		
.1271	-3.2061	-0.0056			.1237	-3.3272	-0.0755		
.1993	-2.5750	-0.2208			.1980	-2.7480	-0.1970		
.7802	-0.3102	-0.3763			.2502	-2.5198	-0.2826		
.8514	-0.2386	-0.3537			.3001	-2.2420	-0.3391		
.9016	-0.1398	-0.3247			.3476	-2.1343	-0.3917		
.9511	0.0755	-0.1109			.4495	-1.6580	-0.4536		
					.4974	-1.4782	-0.4604		
					.5484	-1.0369	-0.4274		
					.6007	-1.0173	-0.4722		
					.6514	-0.8273	-0.4436		
					.7000	-0.6806	-0.4057		
					.7795	-0.3890	-0.3139		
					.8547	-0.3099	-0.2752		
					.9033	-0.1660	-0.2260		
					.9522	0.6946	-0.0177		

y/s = 0.856				
x/c	Upper		Lower	
	Real	Imag	Real	Imag
.1955	-3.1211	-0.2731		
.2458	-2.8152	-0.2711		
.2915	-2.6187	-0.2752		
.3454	-2.2937	-0.3224		
.4519	-1.5923	-0.3647		
.5497	-1.0690	-0.3391		
.6025	-0.8918	-0.3299		
.6545	-0.7304	-0.3375		
.7049	-0.5528	-0.3102		
.7808	-0.0550	-0.0262		

(a-1) Tabulated data for test case 9E23 (point .40-D-5)
Figure 6. Dynamic test cases.

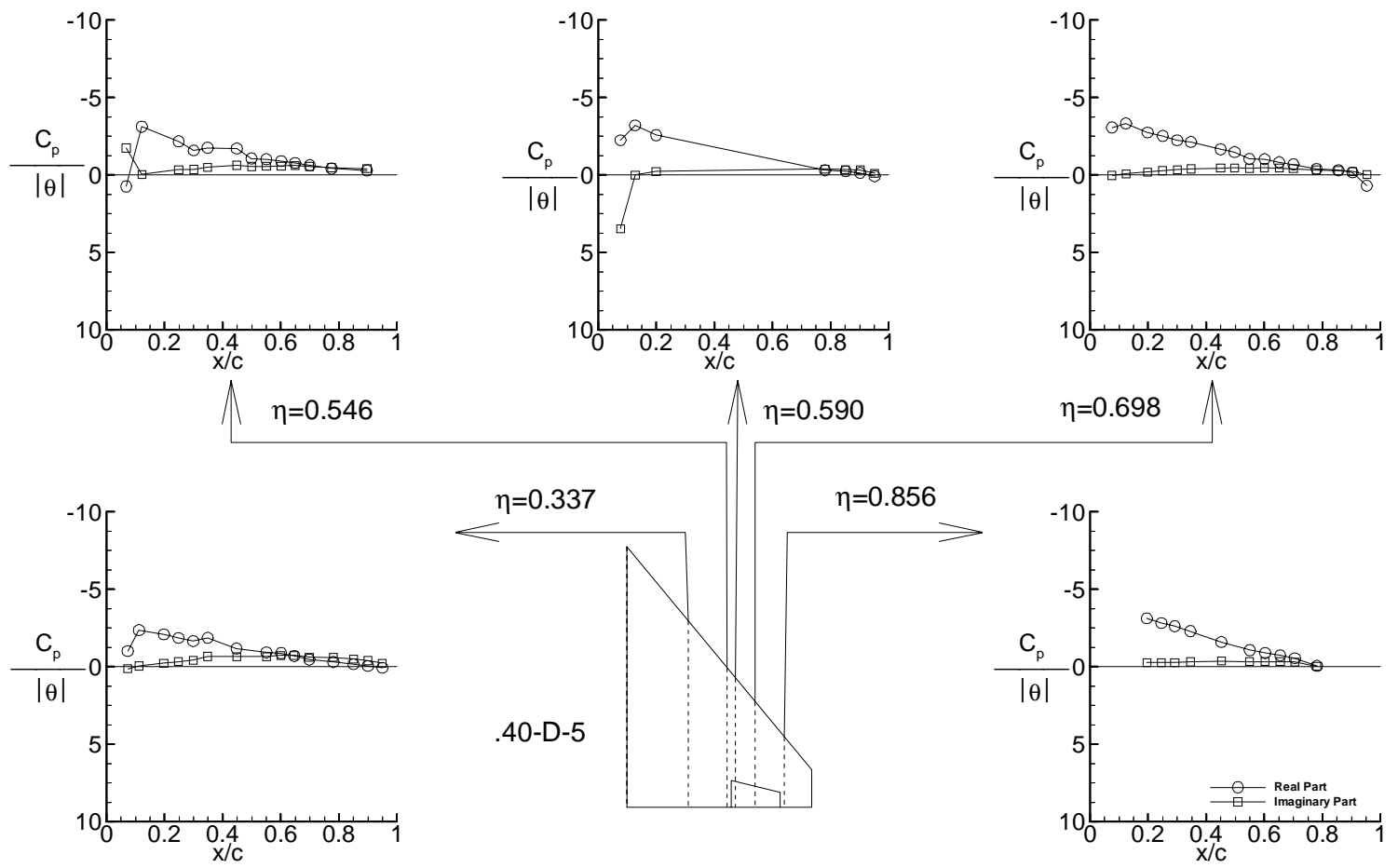

(a-2) Plot of data for test case 9E23 (point .40-D-5)
Figure 6. Continued.

.88-D-5

MACH	q	To	H	ALPHAo	THETA	DELTA	RN
	psf	deg R	psf	deg	deg	deg	
0.885	185.5	556.6	644.0	0.05	0.48	0.00	9.83*10**6

f = 7.98 Hz k = 0.173

y/s = 0.337				y/s = 0.546					
x/c	Upper		Lower		x/c	Upper		Lower	
	Real	Imag	Real	Imag		Real	Imag	Real	Imag
.0731	-2.5014	0.7173			.0681	-3.5404	0.7396		
.1120	-0.1255	-0.1439			.1217	0.0156	0.1183		
.1974	-2.2288	0.2618			.2485	-2.7309	0.1192		
.2478	-2.2410	0.1174			.3004	-2.5306	0.0000		
.2987	-2.2775	-0.1034			.3481	-2.6798	-0.1780		
.3486	-2.4758	-0.1862			.4487	-3.0073	-0.3852		
.4477	-1.8719	-0.3132			.4997	-2.2419	-0.6259		
.5506	-1.6537	-0.5501			.5500	-2.0357	-0.8557		
.6009	-1.9491	-0.8153			.6014	-2.0045	-1.1111		
.6459	-2.0964	-1.1668			.6494	-1.9549	-1.7174		
.6979	-1.3098	-1.3236			.6995	-0.6239	-1.3947		
.7805	-0.1313	-1.4024			.7747	0.1526	-0.7851		
.8500	0.2156	-0.6453			.8964	0.1249	-0.3483		
.8996	0.4375	-0.4403							
.9495	0.4350	-0.2492							

y/s = 0.590				y/s = 0.698					
x/c	Upper		Lower		x/c	Upper		Lower	
	Real	Imag	Real	Imag		Real	Imag	Real	Imag
.0767	-4.2829	1.0282			.0754	0.0460	-0.0129		
.1271	0.0972	-0.0692			.1237	0.1108	-0.2899		
.1993	-2.8626	0.3870			.1980	-3.9302	0.5944		
.7802	-0.1086	-0.3034			.2502	-3.5802	0.4206		
.8514	-0.0835	-0.2615			.3001	-3.6274	0.3110		
.9016	0.1548	-0.1490			.3476	-4.0346	0.0141		
.9511	0.3338	0.0164			.4495	-3.7190	-0.3581		
					.4974	-2.5456	-0.7783		
					.5484	-3.0266	-1.1076		
					.6007	-2.5616	-1.2827		
					.6514	-1.6165	-1.3231		
					.7000	-0.6185	-1.3447		
					.7795	-0.2490	-0.2737		
					.8547	0.0773	-0.4712		
					.9033	0.1803	-0.4806		
					.9522	0.2888	-0.3341		

y/s = 0.856				
x/c	Upper		Lower	
	Real	Imag	Real	Imag
.1955	-4.2931	0.1874		
.2458	-4.7860	0.0752		
.2915	-4.1658	-0.0291		
.3454	-3.7387	-0.3996		
.4519	-2.5100	-0.6866		
.5497	-1.2921	-1.1153		
.6025	0.0000	0.0000		
.6545	0.0450	-0.4633		
.7049	0.2878	-0.3958		
.7808	0.0000	0.0000		

(b-1) Tabulated data for test case 9E24 (point .88-D-5)
Figure 6. Continued.

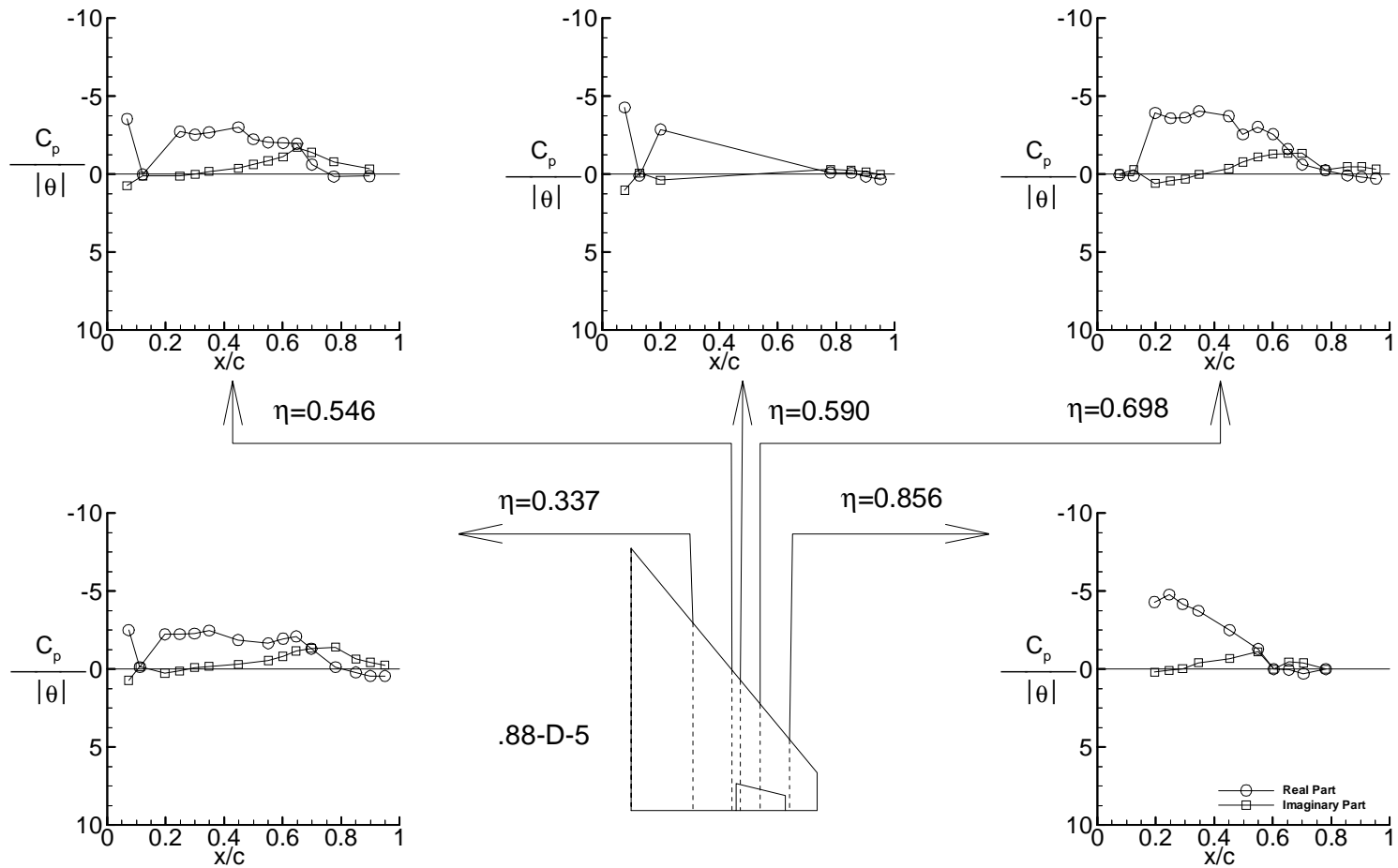

(b-2) Plot of data for test case 9E24 (point .88-D-5)
Figure 6. Continued.

.90-D-5

MACH	q	To	H	ALPHAo	THETA	DELTA	RN
	psf	deg R	psf	deg	deg	deg	
0.904	200.3	566.2	679.5	0.00	0.46	0.00	10.13*10**6

f = 7.99 Hz k = 0.167

y/s = 0.337					y/s = 0.546				
	Upper		Lower			Upper		Lower	
x/c	Real	Imag	Real	Imag	x/c	Real	Imag	Real	Imag
.0731	-2.4667	0.7920			.0681	-3.8789	1.2007		
.1120	-2.1392	0.5334			.1217	-3.2047	0.8407		
.1974	-2.1072	0.3867			.2485	-2.4548	0.4240		
.2478	-2.1140	0.2596			.3004	-2.0958	0.3020		
.2987	-1.0684	0.0766			.3481	-1.3275	0.2174		
.3486	-2.2901	0.0880			.4487	-2.9393	0.0359		
.4477	-1.8757	-0.1377			.4997	-2.1027	-0.0992		
.5506	-2.0993	-0.1542			.5500	-2.4586	0.1935		
.6009	-2.1938	-0.4623			.6014	-2.6647	0.0651		
.6459	-2.5171	-0.6136			.6494	-4.7044	-0.1889		
.6979	-4.0662	-0.8791			.6995	-4.5903	-2.0919		
.7805	0.2918	-3.4253			.7747	1.0737	-2.1090		
.8500	0.8783	-0.8655			.8964	0.3784	-0.5410		
.8996	0.7067	-0.4199							
.9495	0.4162	-0.1668							

y/s = 0.590					y/s = 0.698				
	Upper		Lower			Upper		Lower	
x/c	Real	Imag	Real	Imag	x/c	Real	Imag	Real	Imag
.0767	-3.6778	1.2163			.0754	-2.2762	0.2674		
.1271	-3.2311	0.9326			.1237	-4.1315	1.0378		
.1993	-2.9437	0.7558			.1980	-3.8566	0.7217		
.7802	1.6063	-1.4734			.2502	0.6121	-3.4714		
.8514	0.3705	-0.2741			.3001	-1.4630	0.1409		
.9016	0.6694	-0.3851			.3476	-3.2697	0.3494		
.9511	0.6307	-0.0754			.4495	-3.1492	0.3032		
					.4974	-2.9312	0.3495		
					.5484	-2.5658	0.0134		
					.6007	-3.1078	-0.1955		
					.6514	-4.3593	-1.4164		
					.7000	-2.1524	-2.9626		
					.7795	0.6742	-0.4254		
					.8547	0.5982	-0.1213		
					.9033	0.5532	-0.1917		
					.9522	0.6080	-0.0529		

y/s = 0.856				
	Upper		Lower	
x/c	Real	Imag	Real	Imag
.1955	-3.1322	0.5975		
.2458	-4.2549	0.8271		
.2915	-4.8539	1.0672		
.3454	-1.7394	3.0372		
.4519	-3.6992	0.0323		
.5497	-4.8832	-0.6950		
.6025	-4.2134	-2.8634		
.6545	1.1374	-4.1181		
.7049	3.4864	-0.9446		
.7808	1.0075	0.0537		

(c-1) Tabulated data for test case 9E26 (point.90-D-5)
Figure 6. Continued.

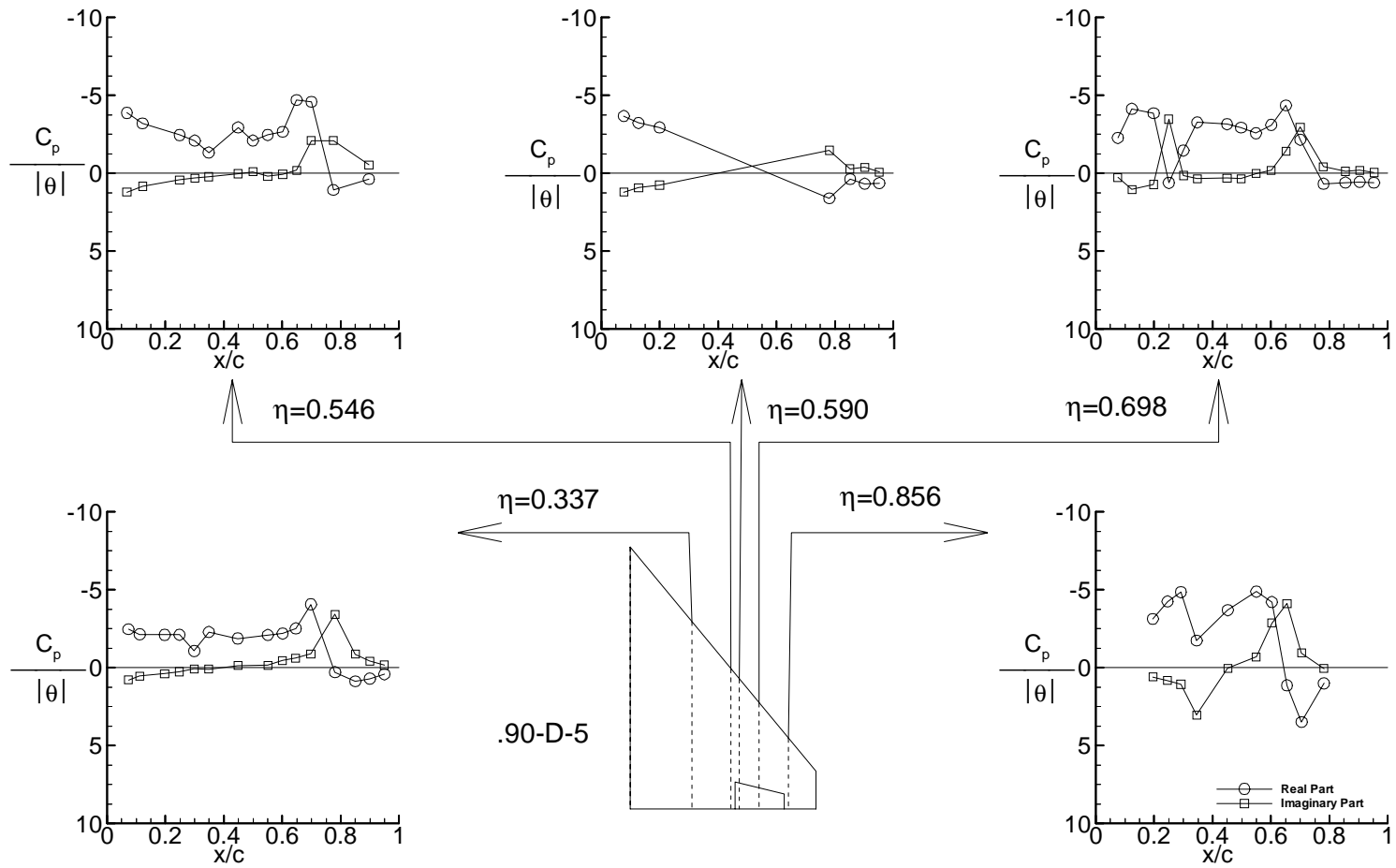

(c-2) Plot of data for test case 9E25 (point.90-D-5)
Figure 6. Continued.

.92-D-5

MACH	q	To	H	ALPHAo	THETA	DELTA	RN
	psf	deg R	psf	deg	deg	deg	
0.921	198.5	556.1	659.2	0.05	0.47	0.00	10.21*10**6

f = 7.97 Hz k = 0.166

y/s = 0.337					y/s = 0.546				
Upper			Lower		Upper			Lower	
x/c	Real	Imag	Real	Imag	x/c	Real	Imag	Real	Imag
.0731	-2.3255	0.8098			.0681	-3.2648	0.7059		
.1120	-0.0780	-0.1238			.1217	0.1293	0.1461		
.1974	-2.2100	0.4496			.2485	-2.3795	0.2166		
.2478	-2.1192	0.2452			.3004	-1.7552	-0.0306		
.2987	-1.8615	0.1171			.3481	-1.9941	-0.1429		
.3486	-1.8128	0.1141			.4487	-3.1511	0.1983		
.4477	-1.7634	0.2416			.4997	0.0000	0.0000		
.5506	-1.5593	-0.0572			.5500	-1.6921	-0.2228		
.6009	-1.6203	0.0594			.6014	-1.5734	-0.4393		
.6459	-1.7940	0.2841			.6494	-1.7845	-0.4516		
.6979	-1.5871	-0.2656			.6995	-2.2703	-0.2066		
.7805	-3.5438	-0.1609			.7747	-4.1636	-1.0381		
.8500	-0.0296	-2.0966			.8964	0.3559	-0.4333		
.8996	0.9850	-0.9278							
.9495	0.7045	-0.4368							

y/s = 0.590					y/s = 0.698				
Upper			Lower		Upper			Lower	
x/c	Real	Imag	Real	Imag	x/c	Real	Imag	Real	Imag
.0767	-3.2424	0.5659			.0754	0.0315	-0.0186		
.1271	0.0258	-0.1066			.1237	-0.2332	-0.1325		
.1993	-2.6226	0.4295			.1980	-2.8269	0.3822		
.7802	-7.3969	0.7644			.2502	-2.0793	0.1490		
.8514	-0.1635	-0.8996			.3001	-2.2732	0.1709		
.9016	0.6101	-0.7451			.3476	-3.2166	0.4980		
.9511	0.8416	-0.2893			.4495	-2.0824	-0.0946		
					.4974	-2.6302	0.1240		
					.5484	-1.7392	-0.2382		
					.6007	-1.7343	-0.1762		
					.6514	-1.8647	-0.0423		
					.7000	-2.0960	0.0585		
					.7795	-3.9876	2.2104		
					.8547	0.1187	-0.3844		
					.9033	0.3906	-0.3676		
					.9522	0.0000	0.0000		

y/s = 0.856				
Upper			Lower	
x/c	Real	Imag	Real	Imag
.1955	-1.9589	0.2509		
.2458	-3.2871	0.5206		
.2915	-3.9284	0.6011		
.3454	-3.3481	0.1696		
.4519	-3.1038	0.5083		
.5497	-2.6725	0.2244		
.6025	-1.9772	-0.1974		
.6545	-1.5155	-0.4633		
.7049	-1.8074	-1.2008		
.7808	0.0000	0.0000		

(d-1) Tabulated data for test case 9E26 (point.92-D-5)
Figure 6. Continued.

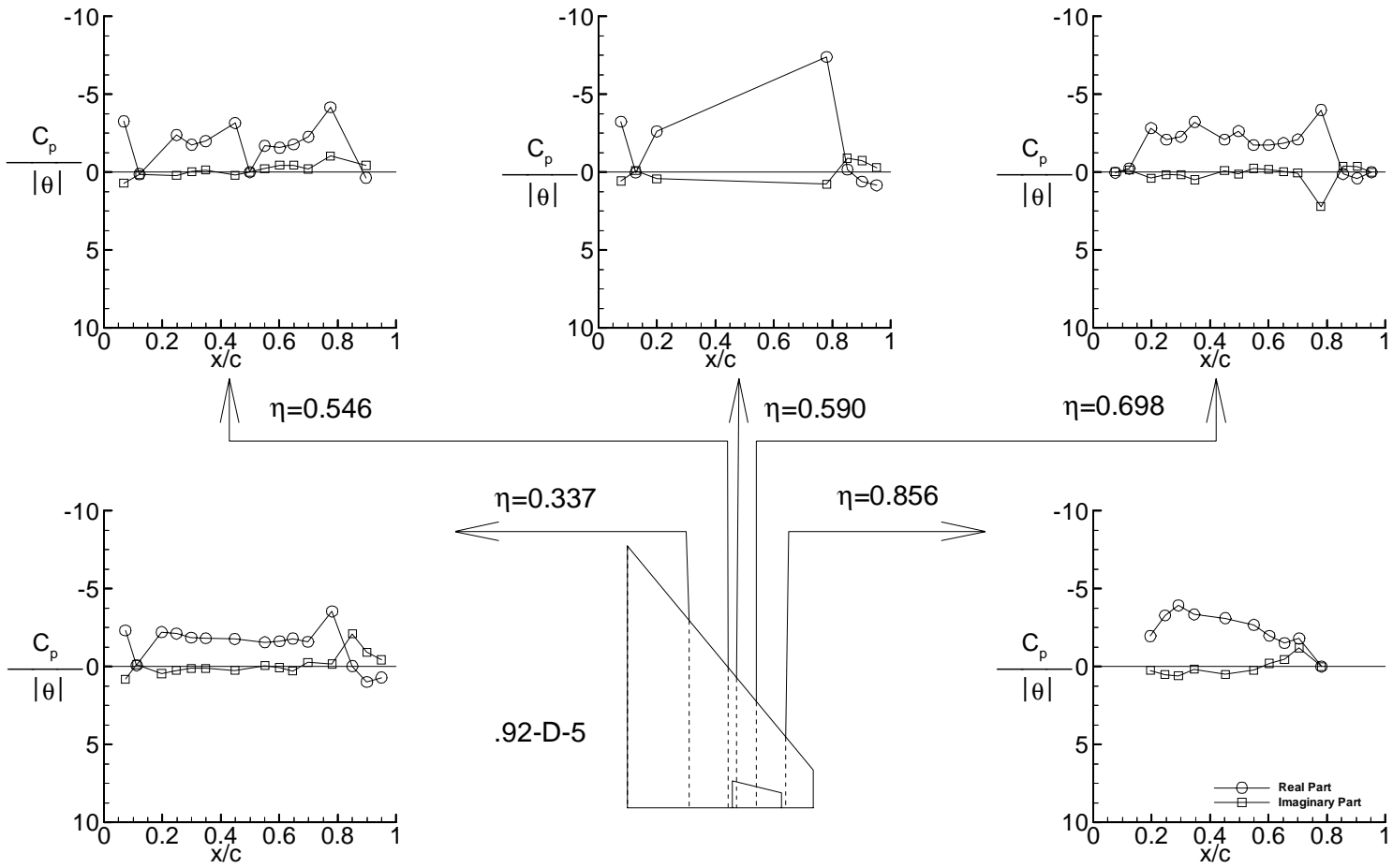

(d-2) Plot of data for test case 9E26 (point.92-D-5)
Figure 6. Continued.

.94-D-5

MACH	q	To	H	ALPHAo	THETA	DELTA	RN
	psf	deg R	psf	deg	deg	deg	
0.945	203.9	563.3	658.8	0.05	0.47	0.00	10.06*10**6

f = 7.98 Hz k = 0.162

y/s = 0.337				y/s = 0.546					
Upper		Lower		Upper		Lower			
x/c	Real	Imag	Real	Imag	x/c	Real	Imag	Real	Imag
.0731	-1.0737	1.0813			.0681	-0.2515	-0.0930		
.1120	-1.8698	0.2728			.1217	-3.2150	0.7600		
.1974	-1.8674	0.1930			.2485	-2.0958	0.2351		
.2478	-1.7889	0.1063			.3004	-1.7216	0.1809		
.2987	-1.7308	0.0302			.3481	-2.1696	0.3281		
.3486	-1.8145	-0.0824			.4487	-2.3619	-0.1197		
.4477	-1.3993	-0.0856			.4997	-1.9577	-0.1403		
.5506	-1.1634	-0.2114			.5500	-1.5962	0.0502		
.6009	-1.4447	-0.1315			.6014	-1.8297	0.2020		
.6459	-1.1174	-0.2539			.6494	-1.7658	0.0802		
.6979	-1.4083	-0.1282			.6995	-1.5444	-0.1080		
.7805	-1.6693	0.0525			.7747	-1.9738	0.0655		
.8500	-0.8413	-0.8990			.8964	0.0242	-0.6822		
.8996	0.0948	-0.5403							
.9495	0.4159	-0.2772							

y/s = 0.590				y/s = 0.698					
Upper		Lower		Upper		Lower			
x/c	Real	Imag	Real	Imag	x/c	Real	Imag	Real	Imag
.0767	-2.1690	-0.0644			.0754	0.2965	0.4323		
.1271	-3.0201	0.6254			.1237	-3.2028	0.7042		
.1993	-2.3287	0.3356			.1980	-2.2198	0.2216		
.7802	-1.9749	0.0069			.2502	-2.3399	0.2459		
.8514	2.5984	-1.5214			.3001	-2.2053	0.0732		
.9016	0.4193	-0.5232			.3476	-2.8351	0.1734		
.9511	0.6466	-0.2190			.4495	-2.7339	0.3405		
					.4974	-2.5730	0.4306		
					.5484	-2.2611	0.3743		
					.6007	-1.9251	0.0639		
					.6514	-1.8404	-0.0353		
					.7000	-1.5972	-0.2788		
					.7795	-2.4741	0.0518		
					.8547	1.9277	-0.8250		
					.9033	0.5626	-0.3867		
					.9522	1.0574	-0.4089		

y/s = 0.856			
Upper		Lower	
x/c	Real	Imag	Imag
.1955	-2.8418	0.7455	
.2458	-2.9266	0.5318	
.2915	-3.6964	0.7252	
.3454	-3.9063	0.7947	
.4519	-2.8011	0.6005	
.5497	-2.7612	0.4869	
.6025	-2.4546	0.3144	
.6545	-1.8408	0.0064	
.7049	-1.5379	-0.1779	
.7808	0.0000	0.0000	

(e-1) Tabulated data for test case 9E27 (point.94-D-5)
Figure 6. Continued.

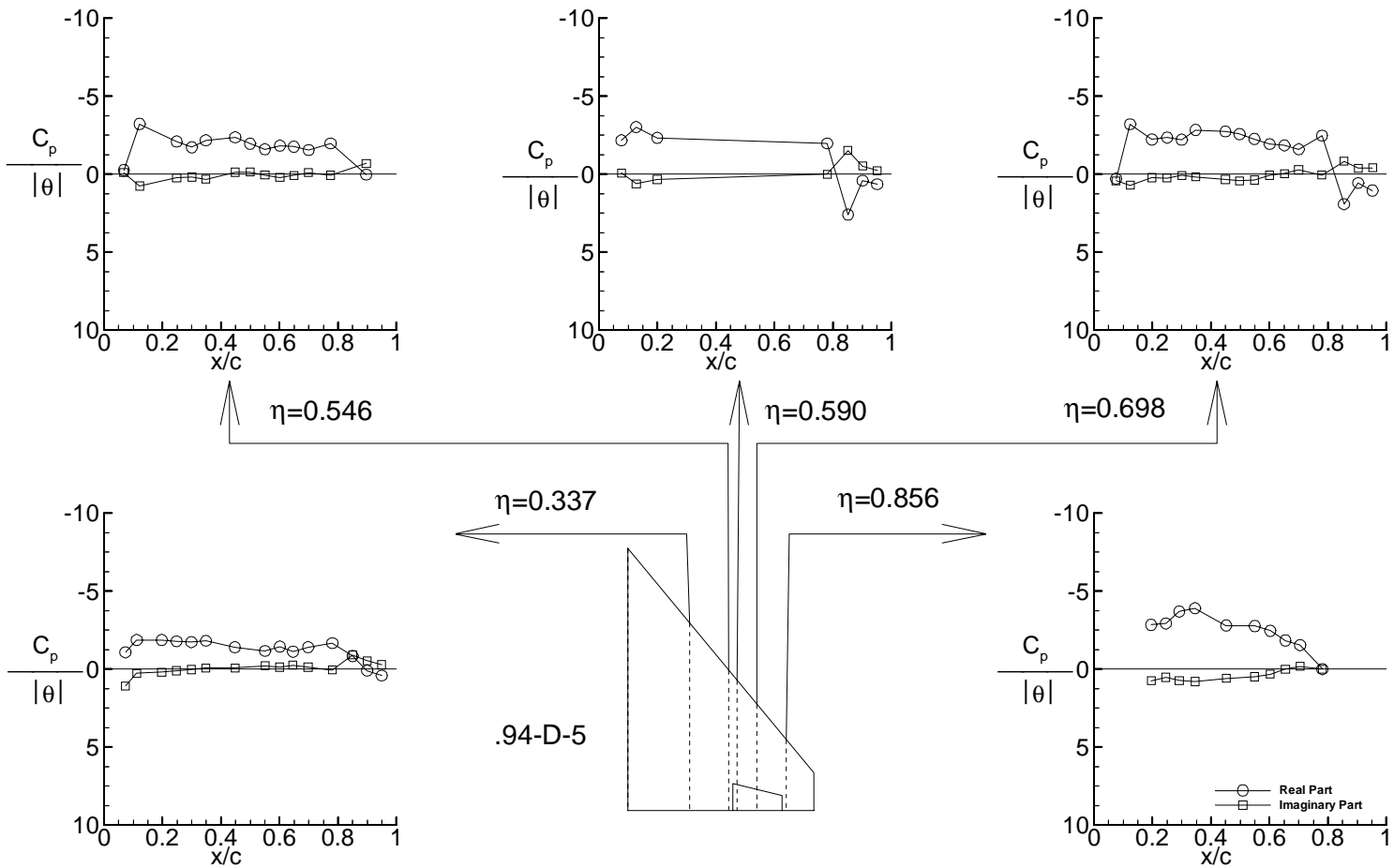

(e-2) Plot of data for test case 9E27 (point.94-D-5)
Figure 6. Continued.

.96-D-4

MACH	q	To	H	ALPHAo	THETA	DELTA	RN
	psf	deg R	psf	deg	deg	deg	
0.961	207.2	564.8	658.1	0.04	0.50	0.00	10.10*10**6

f = 7.99 Hz k = 0.158

y/s = 0.337				y/s = 0.546					
Upper			Lower	Upper			Lower		
x/c	Real	Imag	Real	Imag	x/c	Real	Imag	Real	Imag
.0731	-2.0913	0.6835			.0681	-2.5140	0.7114		
.1120	-1.6958	0.3977			.1217	-1.9680	0.4907		
.1974	-1.7830	0.3144			.2485	-2.2143	0.1976		
.2478	-1.7751	0.2117			.3004	-1.6600	0.0725		
.2987	-0.7777	0.0489			.3481	-0.8700	-0.0395		
.3486	0.0000	0.0000			.4487	0.0000	0.0000		
.4477	-1.5920	-0.1983			.4997	-2.1969	0.1190		
.5506	-1.5520	-0.1412			.5500	-1.4061	-0.2733		
.6009	-1.3457	-0.4191			.6014	-1.3507	-0.4027		
.6459	-1.2125	-0.3001			.6494	-1.7615	-0.3043		
.6979	-1.7221	-0.1689			.6995	-1.4709	-0.2356		
.7805	-1.6091	-0.3656			.7747	-1.7811	-0.2535		
.8500	-1.4293	-0.7536			.8964	1.2107	0.5487		
.8996	5.0924	-1.2697							
.9495	0.6290	0.0396							

y/s = 0.590				y/s = 0.698					
Upper			Lower	Upper			Lower		
x/c	Real	Imag	Real	Imag	x/c	Real	Imag	Real	Imag
.0767	-3.0218	0.8097			.0754	-4.2733	1.0496		
.1271	-2.6513	0.4010			.1237	-2.7874	0.4915		
.1993	-2.0474	0.1252			.1980	-2.1942	0.2772		
.7802	-1.6133	-0.2874			.2502	-2.6866	0.5320		
.8514	-2.3245	1.0889			.3001	-1.0653	0.0298		
.9016	-0.0062	-0.0221			.3476	0.0343	0.0020		
.9511	1.5163	-0.8096			.4495	-2.6696	0.0466		
					.4974	-2.5553	0.0268		
					.5484	-2.3720	-0.0207		
					.6007	-1.7244	-0.2454		
					.6514	-1.6916	-0.2317		
					.7000	-1.6050	-0.1857		
					.7795	-2.3151	0.2270		
					.8547	-6.5505	3.3233		
					.9033	16.8142	-11.1164		
					.9522	3.0698	-2.0057		

y/s = 0.856				
Upper			Lower	
x/c	Real	Imag	Real	Imag
.1955	-3.0564	0.5499		
.2458	-2.8014	0.3142		
.2915	-3.3182	0.4310		
.3454	-3.6068	0.5197		
.4519	-2.9820	0.5097		
.5497	-3.0320	0.3133		
.6025	-2.2689	0.0079		
.6545	-1.7199	-0.1899		
.7049	-1.4919	-0.2497		
.7808	-1.3271	-0.5688		

(f-1) Tabulated data for test case 9E28 (point.94-D-4)
Figure 6. Continued.

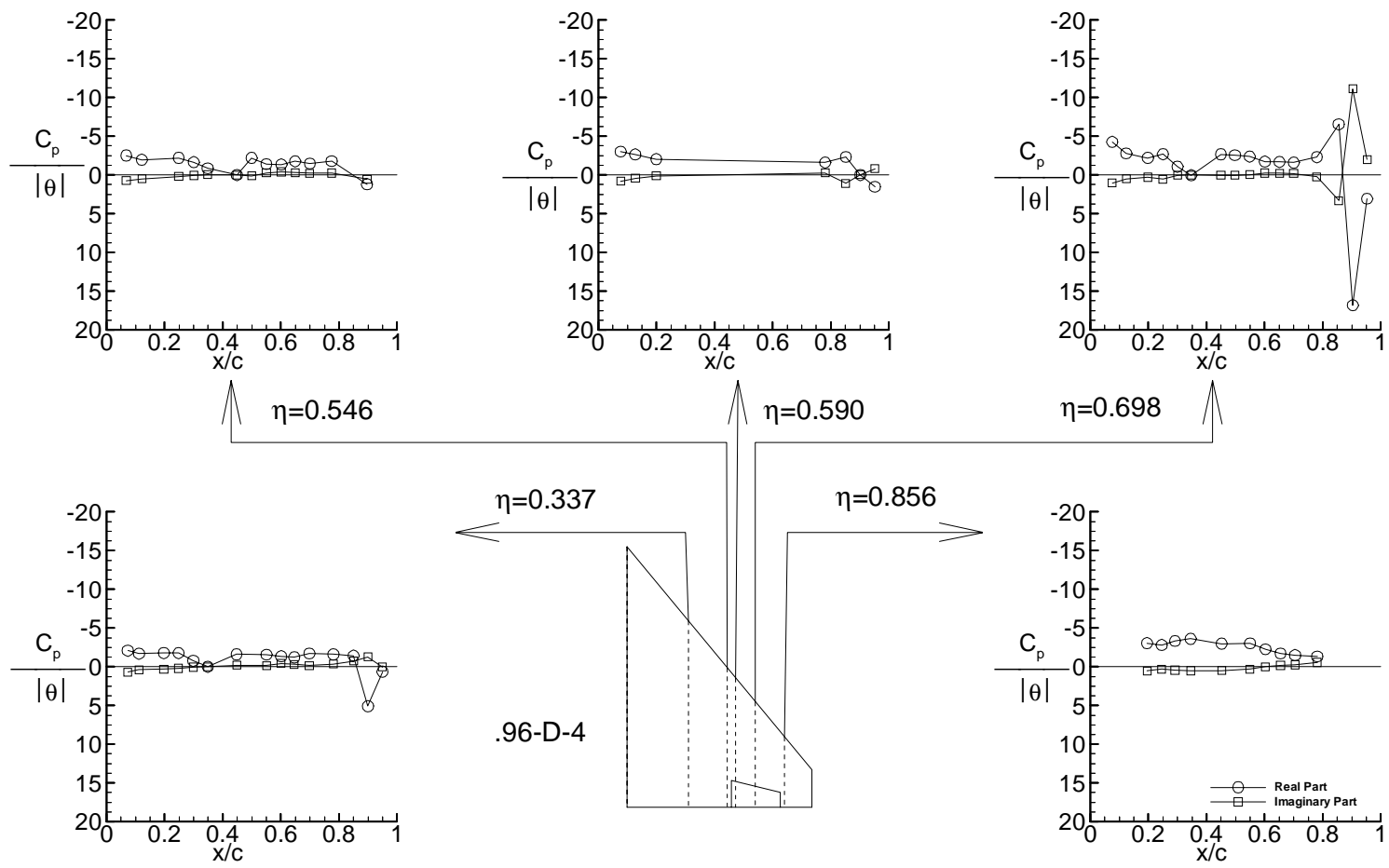

(f-2) Plot of data for test case 9E28 (point.96-D-4)
Figure 6. Continued.

1.12-D-5

MACH	q	To	H	ALPHAo	THETA	DELTA	RN
	psf	deg R	psf	deg	deg	deg	
1.120	232.4	575.4	646.1	0.00	0.47	0.00	9.67*10**6

f = 8.00 Hz k = 0.136

y/s = 0.337					y/s = 0.546				
Upper			Lower		Upper			Lower	
x/c	Real	Imag	Real	Imag	x/c	Real	Imag	Real	Imag
.0731	-1.7680	0.3597			.0681	-5.8878	4.2153		
.1120	-2.3646	0.6424			.1217	-2.6376	0.4130		
.1974	-1.7999	0.3859			.2485	-2.2896	0.3504		
.2478	-1.7603	0.3358			.3004	-1.6289	0.1225		
.2987	-0.9459	0.4231			.3481	-0.7635	-0.0829		
.3486	-1.6414	-0.2336			.4487	-2.0097	0.0842		
.4477	-1.4125	-0.2720			.4997	-1.6335	0.0114		
.5506	-1.4408	-0.1693			.5500	-1.7765	0.1087		
.6009	-1.5846	0.0249			.6014	-1.9105	0.2447		
.6459	-0.9547	-0.3703			.6494	-1.3837	-0.2916		
.6979	-1.2802	-0.3074			.6995	-1.0776	-0.3522		
.7805	-1.2994	-0.3312			.7747	-1.3775	-0.2603		
.8500	-1.1141	-0.5242			.8964	-1.0775	-0.3110		
.8996	-1.2943	-0.5388							
.9495	-1.2276	-0.5085							

y/s = 0.590					y/s = 0.698				
Upper			Lower		Upper			Lower	
x/c	Real	Imag	Real	Imag	x/c	Real	Imag	Real	Imag
.0767	-2.4843	0.7124			.0754	-3.1803	1.0211		
.1271	-2.5238	0.6106			.1237	-1.0096	0.2331		
.1993	-2.3984	0.5581			.1980	-2.8866	0.3954		
.7802	-1.3899	-0.1830			.2502	-1.2242	0.2181		
.8514	-0.6703	-0.0176			.3001	-0.8351	0.1011		
.9016	-1.1950	-0.2410			.3476	-1.6361	0.1777		
.9511	-0.9949	-0.1844			.4495	-1.6743	0.1642		
					.4974	-2.4126	0.2536		
					.5484	-2.9903	0.5219		
					.6007	-1.3086	0.2307		
					.6514	-1.7213	0.1839		
					.7000	1.3880	-0.0689		
					.7795	-0.5481	-0.2049		
					.8547	0.6503	0.1632		
					.9033	0.9514	0.1497		
					.9522	0.0000	0.0000		

y/s = 0.856				
Upper			Lower	
x/c	Real	Imag	Real	Imag
.1955	-3.1790	0.6989		
.2458	-2.6284	0.4682		
.2915	-2.6007	0.4119		
.3454	-2.4403	0.3299		
.4519	-2.5746	0.4911		
.5497	-2.4762	0.4858		
.6025	-1.6953	1.2545		
.6545	-2.4221	0.3706		
.7049	-2.3134	0.2636		
.7808	-2.5947	0.0997		

(g-1) Tabulated data for test case 9E29 (point 1.12-D-5)
Figure 6. Continued.

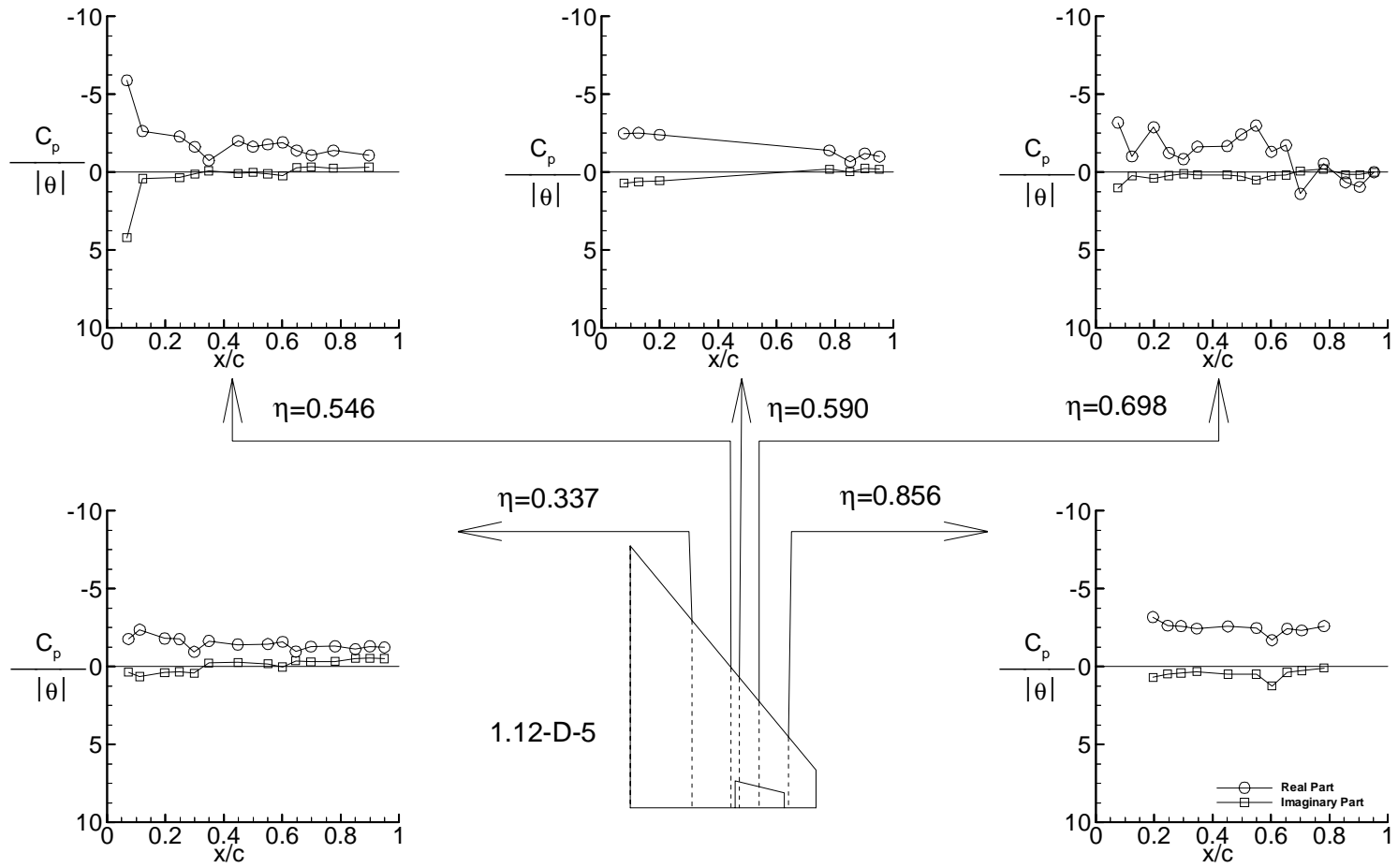

(g-2) Plot of data for test case 9E29 (point 1.12-D-5)
Figure 6. Continued.

.90-D-2

MACH	q	To	H	ALPHAo	THETA	DELTA	RN
	psf	deg R	psf	deg	deg	deg	
0.905	200.6	565.2	679.3	0.00	0.24	0.00	10.16*10**6

f = 7.99 Hz k = 0.168

y/s = 0.337					y/s = 0.546				
Upper			Lower		Upper			Lower	
x/c	Real	Imag	Real	Imag	x/c	Real	Imag	Real	Imag
.0731	-2.4706	0.5477			.0681	-3.2896	1.1520		
.1120	-1.9283	0.1450			.1217	-2.7524	0.7944		
.1974	-1.9301	0.1181			.2485	-1.9360	0.4221		
.2478	-1.8859	0.0132			.3004	-1.4917	0.3307		
.2987	-0.9044	-0.0712			.3481	-0.9541	0.2185		
.3486	-1.9531	-0.1331			.4487	-2.3252	0.5411		
.4477	-1.3880	-0.3538			.4997	-1.4500	0.1345		
.5506	-1.6467	-0.2844			.5500	-1.6481	0.4882		
.6009	-1.5743	-0.5606			.6014	-1.7483	0.8264		
.6459	-1.3899	-0.7421			.6494	-3.2120	1.6366		
.6979	-2.2528	-0.7146			.6995	-4.4015	1.3625		
.7805	-0.5408	-1.3521			.7747	-1.0212	-2.3154		
.8500	0.7294	-0.5787			.8964	0.0899	-0.2970		
.8996	0.6141	-0.2641							
.9495	0.3101	0.0131							

y/s = 0.590					y/s = 0.698				
Upper			Lower		Upper			Lower	
x/c	Real	Imag	Real	Imag	x/c	Real	Imag	Real	Imag
.0767	-3.4570	1.1033			.0754	-3.1090	0.5147		
.1271	-3.0337	0.8527			.1237	-3.5516	1.0386		
.1993	-2.7310	0.6910			.1980	-3.8563	1.0117		
.7802	2.9421	-3.0992			.2502	-3.4947	0.7812		
.8514	0.6948	-0.3175			.3001	-1.4205	0.1845		
.9016	0.9133	-0.4137			.3476	-3.1097	0.3323		
.9511	0.7232	-0.1572			.4495	-3.1663	0.4563		
					.4974	-2.9750	0.4446		
					.5484	-2.4825	0.0390		
					.6007	-3.6046	-0.0440		
					.6514	-4.2792	-1.6426		
					.7000	-1.8661	-2.8301		
					.7795	0.4883	-0.1933		
					.8547	0.4710	-0.4743		
					.9033	0.3958	-0.4142		
					.9522	0.4764	-0.2211		

y/s = 0.856				
Upper			Lower	
x/c	Real	Imag	Real	Imag
.1955	-1.9893	0.8118		
.2458	-2.4262	1.0049		
.2915	-3.7578	1.5951		
.3454	-0.8398	3.7263		
.4519	-3.5671	1.0702		
.5497	-4.6357	1.5691		
.6025	-5.6041	1.7562		
.6545	-4.8146	-1.4812		
.7049	1.6753	-4.8516		
.7808	1.0471	-0.5216		

(h-1) Tabulated data for test case 9E30 (point.90-D-2)
Figure 6. Continued.

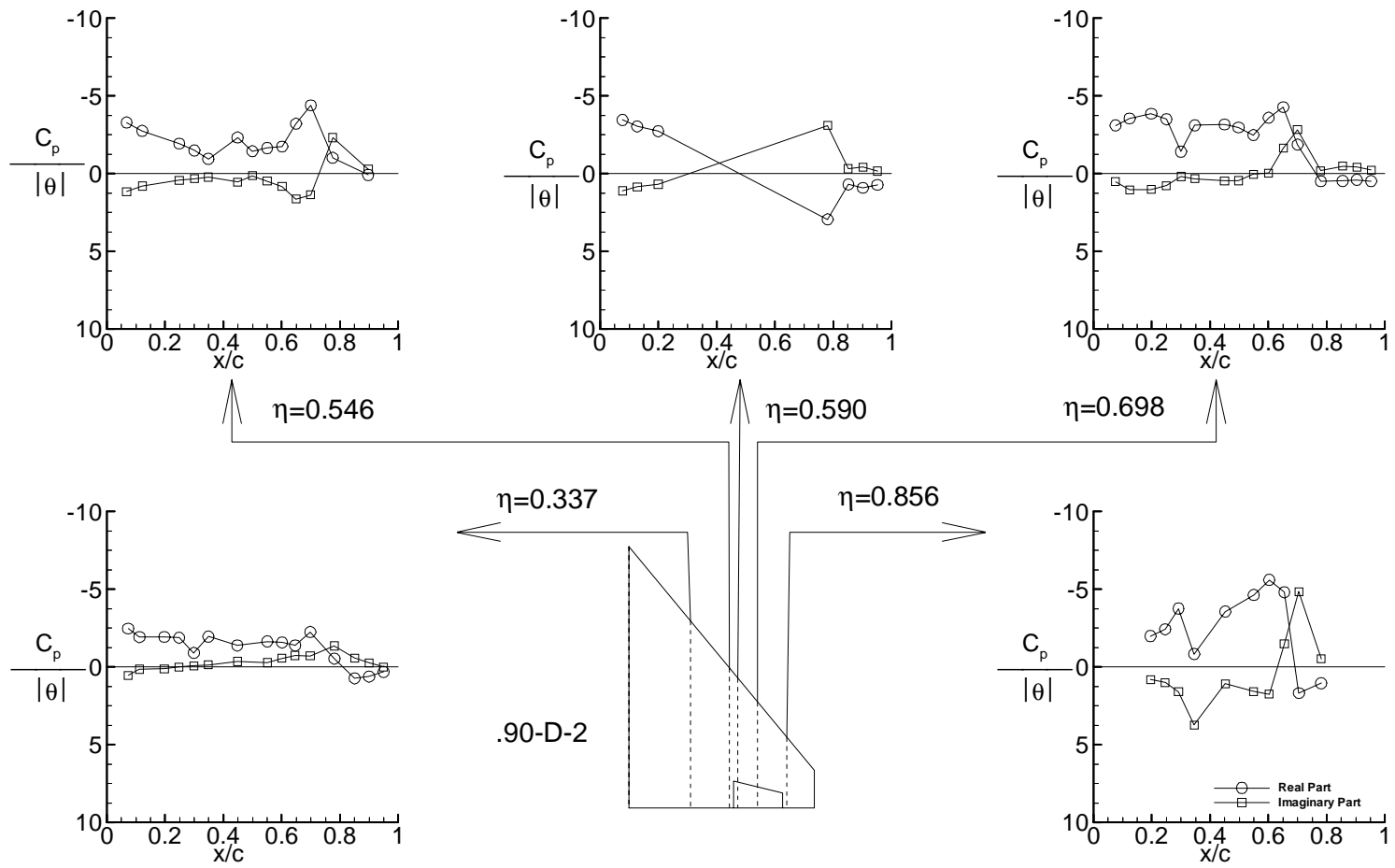

(h-2) Plot of data for test case 9E30 (point.90-D-2)
Figure 6. Continued.

.90-D-4

MACH	q	To	H	ALPHAo	THETA	DELTA	RN
	psf	deg R	psf	deg	deg	deg	
0.904	200.7	566.0	680.9	0.00	0.50	0.00	10.16*10**6

f = 4.01 Hz k = 0.084

y/s = 0.337					y/s = 0.546				
	Upper		Lower			Upper		Lower	
x/c	Real	Imag	Real	Imag	x/c	Real	Imag	Real	Imag
.0731	-2.3063	0.3818			.0681	-3.7350	0.5916		
.1120	-1.9035	0.1967			.1217	-2.9958	0.4210		
.1974	-1.8852	0.1451			.2485	-2.3230	0.1217		
.2478	-1.8898	0.0594			.3004	-1.8558	0.0454		
.2987	-0.9396	0.0131			.3481	-1.2144	0.0276		
.3486	-1.9472	-0.0578			.4487	-2.4266	-0.1144		
.4477	-1.4171	-0.1041			.4997	-1.6122	-0.1071		
.5506	-1.6436	-0.1467			.5500	-2.0053	-0.0070		
.6009	-1.4633	-0.3351			.6014	-1.9042	-0.1901		
.6459	-1.4833	-0.4394			.6494	-2.8022	-0.3988		
.6979	-2.4668	-0.5198			.6995	-2.4046	-1.3110		
.7805	0.0945	-1.2685			.7747	0.3906	-0.9915		
.8500	0.6206	-0.2683			.8964	0.2722	-0.1212		
.8996	0.4751	-0.2538							
.9495	0.3188	-0.1287							

y/s = 0.590					y/s = 0.698				
	Upper		Lower			Upper		Lower	
x/c	Real	Imag	Real	Imag	x/c	Real	Imag	Real	Imag
.0767	-3.4732	0.4819			.0754	-2.1350	0.1830		
.1271	-2.9950	0.3359			.1237	-4.0190	0.5505		
.1993	-2.6492	0.2225			.1980	-3.5918	0.3585		
.7802	0.7835	-0.4976			.2502	-3.2092	0.2638		
.8514	0.2221	-0.0927			.3001	-1.3628	0.0476		
.9016	0.4366	-0.1397			.3476	-2.9666	0.0880		
.9511	0.4232	-0.0254			.4495	-3.2309	0.0620		
					.4974	-2.5315	-0.0707		
					.5484	-2.2160	-0.4307		
					.6007	-2.6140	-0.4845		
					.6514	-2.1180	-1.2130		
					.7000	-0.1434	-0.9054		
					.7795	0.2450	-0.1249		
					.8547	0.2968	0.0260		
					.9033	0.3323	-0.0012		
					.9522	0.4698	-0.0016		

y/s = 0.856				
	Upper		Lower	
x/c	Real	Imag	Real	Imag
.1955	-2.7454	0.1631		
.2458	-3.7066	0.2137		
.2915	-4.2658	0.2684		
.3454	-3.1768	2.1347		
.4519	-2.8293	-0.0790		
.5497	-3.1676	-0.3385		
.6025	-1.3419	-1.4747		
.6545	1.3149	-1.1597		
.7049	1.6409	-0.5843		
.7808	0.5124	0.0583		

(i-1) Tabulated data for test case 9E31 (point.90-D-4)
Figure 6. Continued.

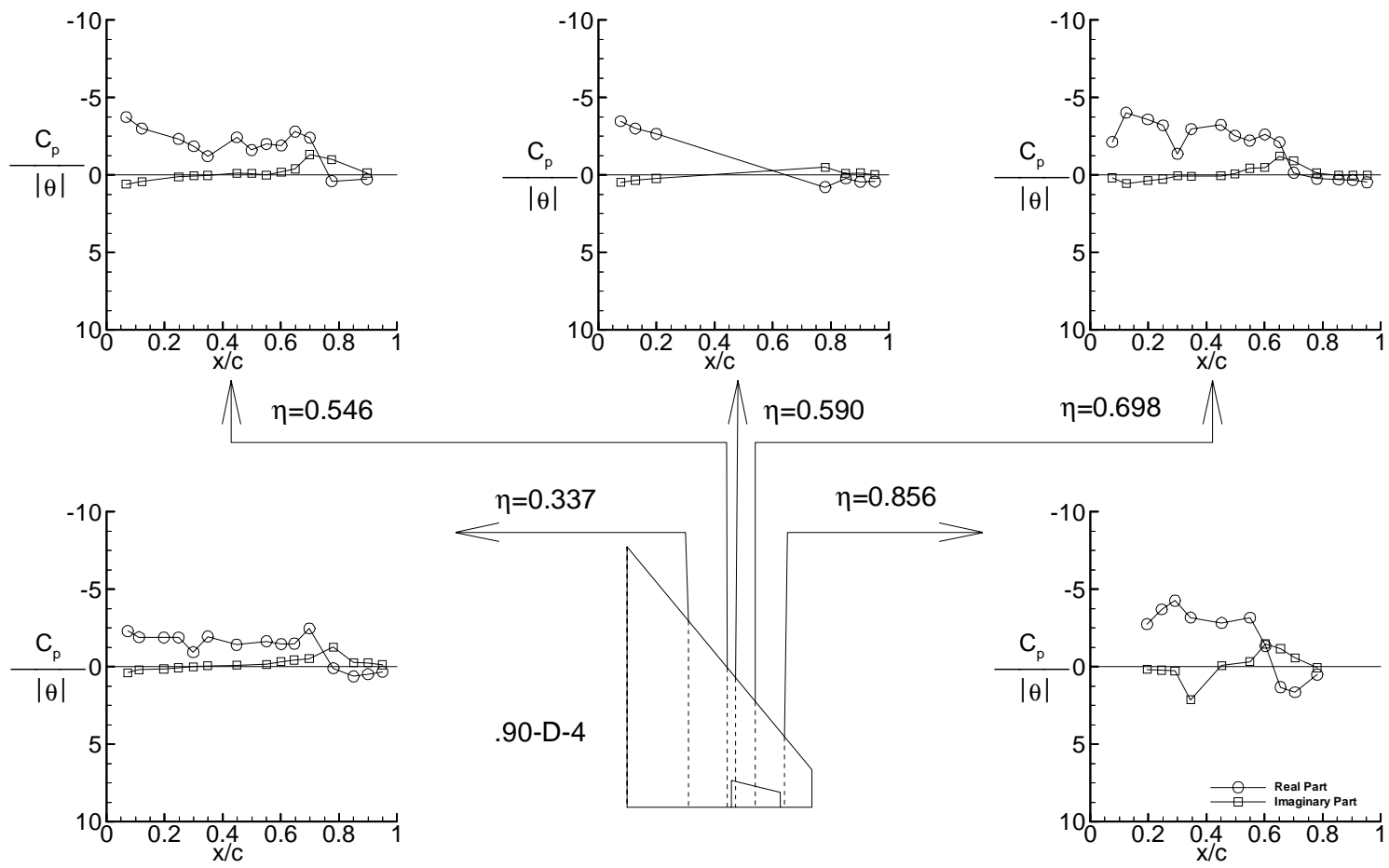

(i-2) Plot of data for test case 9E31 (point.90-D-4)
Figure 6. Continued.

.90-D-6

MACH	q	To	H	ALPHAo	THETA	DELTA	RN
	psf	deg R	psf	deg	deg	deg	
0.909	202.0	564.7	680.6	0.00	0.46	0.00	10.21*10**6

f = 16.01 Hz k = 0.335

y/s = 0.337					y/s = 0.546				
x/c	Upper		Lower		x/c	Upper		Lower	
	Real	Imag	Real	Imag		Real	Imag	Real	Imag
.0731	-3.2013	1.4454			.0681	-4.4649	1.9136		
.1120	-2.9378	0.8258			.1217	-4.0071	1.0214		
.1974	-2.8485	0.4054			.2485	-2.9885	0.0730		
.2478	-2.8398	0.0198			.3004	-2.8749	-0.2920		
.2987	-1.4344	-0.1736			.3481	-1.3599	-0.1670		
.3486	-3.1015	-0.5580			.4487	-3.1827	-0.5269		
.4477	-2.3645	-1.0281			.4997	-1.8978	-0.9670		
.5506	-1.8315	-0.9861			.5500	-1.8701	-0.5717		
.6009	-1.7977	-1.1189			.6014	-1.4292	-0.3431		
.6459	-1.6743	-1.3366			.6494	-1.6621	0.7680		
.6979	-1.5996	-0.1512			.6995	-2.9422	4.0053		
.7805	-3.5021	0.2695			.7747	-6.3361	-2.2936		
.8500	-0.6506	-2.2105			.8964	-0.1796	-1.7345		
.8996	0.2051	-1.5434							
.9495	0.1874	-0.6589							

y/s = 0.590					y/s = 0.698				
x/c	Upper		Lower		x/c	Upper		Lower	
	Real	Imag	Real	Imag		Real	Imag	Real	Imag
.0767	-4.1534	1.5529			.0754	-3.0592	0.6447		
.1271	-3.6346	0.9197			.1237	-4.7576	1.3015		
.1993	-3.2150	0.3891			.1980	-4.2338	0.8691		
.7802	-5.4573	-2.0839			.2502	-3.6528	0.5851		
.8514	-0.5436	-1.3387			.3001	-1.5437	0.0485		
.9016	0.2406	-1.9156			.3476	-3.4828	0.1825		
.9511	0.9513	-0.8974			.4495	-2.7512	0.0913		
					.4974	-2.3782	0.4279		
					.5484	-2.0201	0.3781		
					.6007	-2.1044	1.1095		
					.6514	-3.8462	3.7272		
					.7000	-9.4229	3.0435		
					.7795	-3.3372	-2.6073		
					.8547	-0.2002	-1.9578		
					.9033	0.3603	-1.4634		
					.9522	0.9940	-0.9064		

y/s = 0.856				
x/c	Upper		Lower	
	Real	Imag	Real	Imag
.1955	-2.6405	0.4466		
.2458	-3.3017	0.5703		
.2915	-3.9379	1.0404		
.3454	0.0108	2.0676		
.4519	-2.9237	0.6804		
.5497	-3.6609	1.8413		
.6025	-5.9939	3.4189		
.6545	-10.3521	1.9000		
.7049	-4.6050	-6.3383		
.7808	0.9068	-2.7306		

(j-1) Tabulated data for test case 9E32 (point.90-D-6)
Figure 6. Continued.

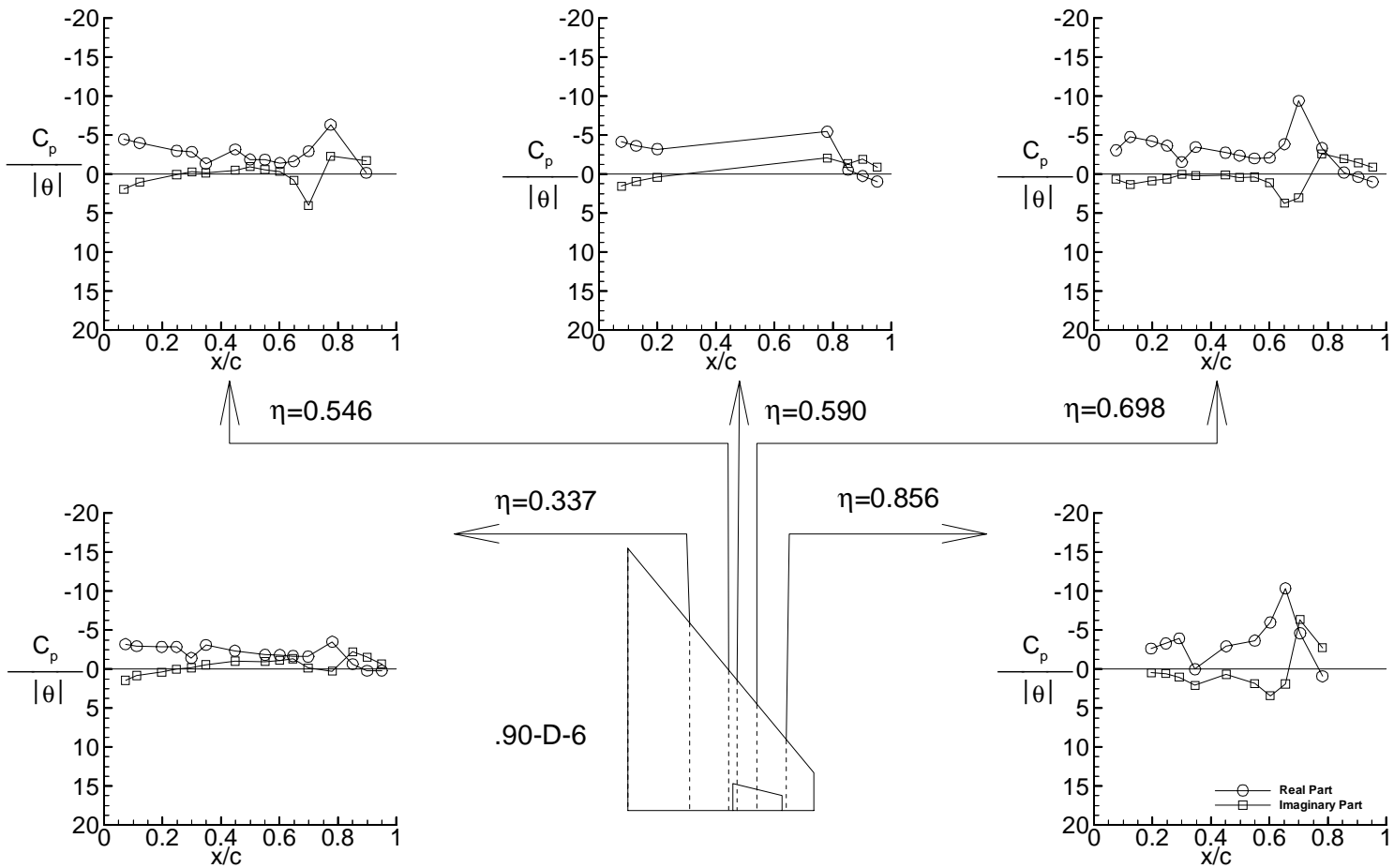

(j-2) Plot of data for test case 9E32 (point 90-D-6)
Figure 6. Continued.

.40-D-24

MACH	q	To	H	ALPHAo	THETA	DELTA	RN
	psf	deg R	psf	deg	deg	deg	
0.403	78.8	532.0	939.0	5.02	0.50	0.00	9.18*10**6

f = 4.00 Hz k = 0.189

y/s = 0.337					y/s = 0.546				
Upper		Lower			Upper		Lower		
x/c	Real	Imag	Real	Imag	x/c	Real	Imag	Real	Imag
.0731	-1.5540	3.2580	3.6177	0.4371	.0681	-0.0439	1.3515	-3.4607	5.6474
.1120	-11.3044	4.4757	-1.9249	-0.0302	.1217	-17.6871	3.5342	-2.1498	-0.1390
.1974	0.2266	-0.9001	-1.7306	-0.1972	.2485	-5.2766	1.8169	-1.6719	-0.3462
.2478	-0.2989	-0.8302	-1.6353	-0.2942	.3004	-1.5772	0.4852	-1.4220	-0.3598
.2987	-0.5346	-0.7866	-1.5272	-0.3638	.3481	-0.4594	-0.3424	-1.4700	-0.4438
.3486	-0.8385	-0.9411	-1.6775	-0.5097	.4487	0.0961	-1.0383	-1.4917	-0.6209
.4477	-0.7590	-0.7643	-1.2039	-0.5360	.4997	-0.0590	-0.7770	-1.0469	-0.5450
.5506	-0.5641	-0.6331	-0.9375	-0.5304	.5500	-0.1625	-0.7269	-0.9540	-0.5244
.6009	-0.6150	-0.6952	-0.9488	-0.5791	.6014	-0.1932	-0.6359	-0.8630	-0.5647
.6459	-0.4817	-0.6557	-0.8150	-0.5333	.6494	-0.2565	-0.6131	-0.8261	-0.5980
.6979	-0.3380	-0.5855	-0.6618	-0.5302	.6995	-0.2689	-0.5189	-0.6323	-0.5120
.7805	-0.1807	-0.4707	-0.4344	-0.4724	.7747	0.0065	-0.4583	-0.4429	-0.4322
.8500	-0.1036	-0.3637	-0.2768	-0.3796	.8964	0.5757	-0.6226	-0.2784	-0.3641
.8996	-0.0729	-0.2413	-0.2172	-0.2811					
.9495	-0.0295	-0.0988	-0.1094	-0.1173					

y/s = 0.590					y/s = 0.698				
Upper		Lower			Upper		Lower		
x/c	Real	Imag	Real	Imag	x/c	Real	Imag	Real	Imag
.0767	0.3357	2.8450	0.9253	-2.0842	.0754	2.6415	-0.3005	1.3062	0.0180
.1271	-12.1279	0.4235	-1.9587	-0.2197	.1237	-19.0148	-0.5311	-1.8982	-0.2432
.1993	-8.8603	2.4405	-1.8502	-0.3296	.1980	-29.5325	3.5738	-2.0075	-0.2893
.7802	-0.0404	-0.4566	-0.3898	-0.3376	.2502	-24.2198	5.1039	-1.7701	-0.3217
.8514	-0.1924	-0.2122	-0.3154	-0.3786	.3001	-13.7670	4.0780	-1.6558	-0.3671
.9016	-0.1929	-0.1438	-0.1993	-0.3480	.3476	-6.7809	2.6711	-1.7234	-0.4297
.9511	-0.0059	-0.1030	-0.0232	-0.1703	.4495	2.4511	-0.6366	-1.3506	-0.4415
					.4974	2.8416	-1.0709	-1.1845	-0.4311
					.5484	2.6555	-1.1635	-0.8800	-0.3900
					.6007	2.1359	-1.2733	-0.8585	-0.4095
					.6514	1.6254	-1.1745	-0.7316	-0.4056
					.7000	1.0208	-1.0373	-0.6123	-0.4037
					.7795	0.7477	-0.5878	-0.3275	-0.3368
					.8547	0.6925	-0.5652	-0.2122	-0.3268
					.9033	0.7114	-0.3181	-0.0727	-0.3125
					.9522	0.3365	-0.1726	0.3576	-0.2680

y/s = 0.856				
Upper		Lower		
x/c	Real	Imag	Real	Imag
.1955	0.6511	-3.5970	-1.9309	-0.3335
.2458	-10.5707	-0.6095	-1.7361	-0.3753
.2915	-19.4605	2.3894	-1.5954	-0.3742
.3454	-26.4105	4.8949	-1.5796	-0.3909
.4519	-21.5129	5.6037	-1.1363	-0.3957
.5497	-11.6255	3.3995	-0.8329	-0.3831
.6025	-6.9364	2.1605	-0.6511	-0.4069
.6545	-2.5283	0.6117	-0.5133	-0.4039
.7049	-1.2087	0.2658	-0.3308	-0.4250
.7808	0.0000	0.0000		

(k-1) Tabulated data for test case 9E33 (point.40-D-24)
Figure 6. Continued.

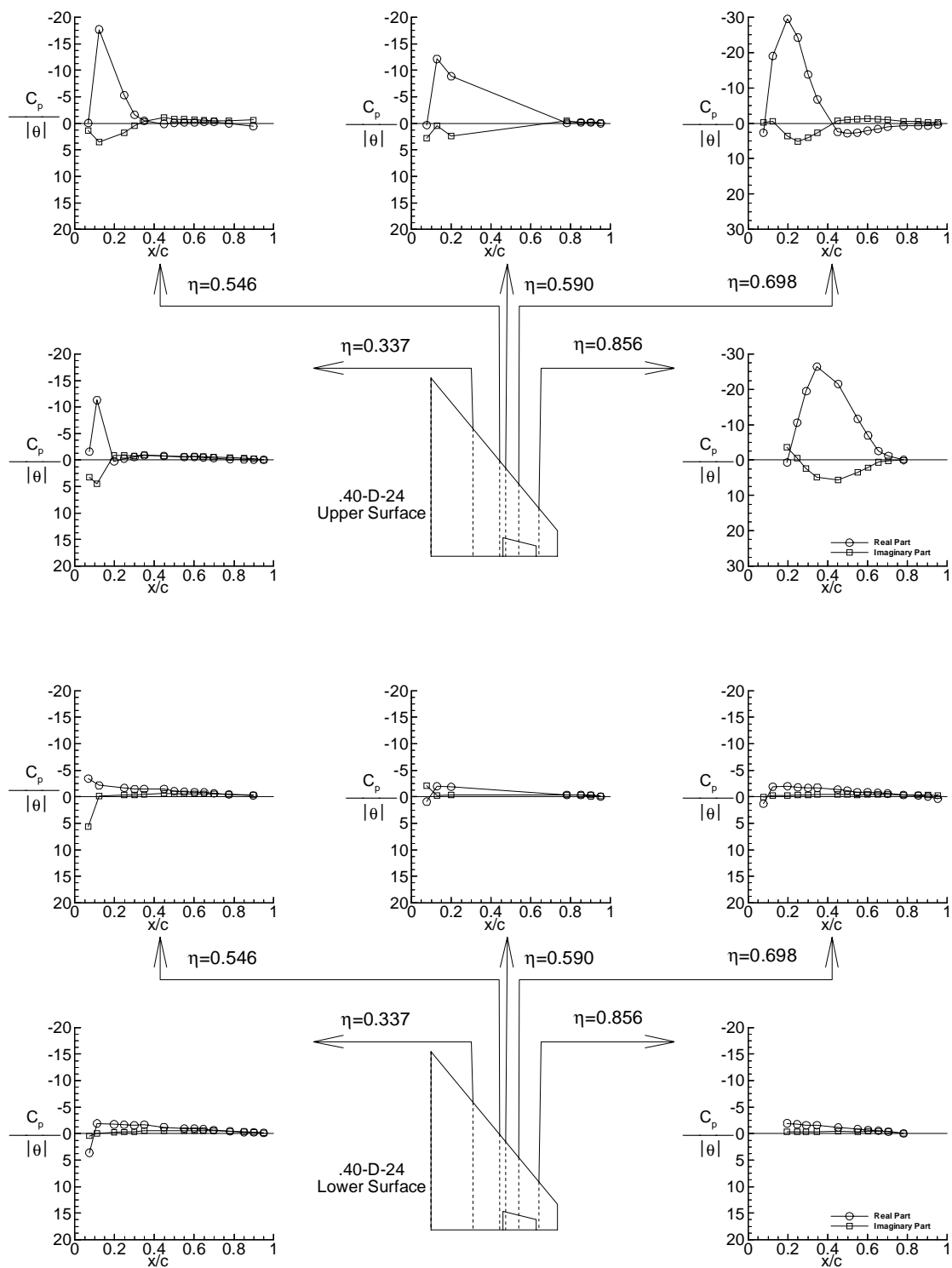

(k-2) Plot of data for test case 9E33 (point .40-D-24)
Figure 6. Continued.

.90-D-29

MACH	q	To	H	ALPHAo	THETA	DELTA	RN
	psf	deg R	psf	deg	deg	deg	
0.902	197.6	567.0	671.7	3.97	0.46	0.00	10.04*10**6

f = 7.99 Hz k = 0.169

y/s = 0.337					y/s = 0.546				
Upper		Lower			Upper		Lower		
x/c	Real	Imag	Real	Imag	x/c	Real	Imag	Real	Imag
.0731	-11.5701	6.2559	-0.3925	-0.2862	.0681	-16.9167	6.9725	-0.1094	-0.8901
.1120	-0.6328	-0.2278	-2.4184	0.4832	.1217	-16.9476	8.0111	-2.5253	0.4544
.1974	-1.8694	0.2064	-2.3677	0.2322	.2485	-0.9190	-1.1470	-2.3489	0.1560
.2478	-2.1264	0.2611	-2.3902	0.0793	.3004	-0.8554	-1.7308	-2.1998	0.1461
.2987	-1.1890	0.1271	-1.2080	-0.0232	.3481	-0.4192	-0.3334	-1.2580	0.0000
.3486	-2.7606	-0.1592	-2.4969	-0.1834	.4487	-1.1719	-0.7098	-2.8273	-0.2673
.4477	-0.6275	-0.9737	-2.1498	-0.3598	.4997	-1.3068	-0.5227	-2.5630	-0.3785
.5506	-1.0756	-0.2682	-1.8456	-0.6463	.5500	-1.3045	-0.4188	-2.2618	-0.5014
.6009	-1.0878	-0.2134	-2.2087	-0.7778	.6014	-1.7017	0.2422	-2.4303	-0.6512
.6459	-1.0583	0.0314	-2.2687	-1.1163	.6494	-1.6384	0.1376	-2.5587	-1.0808
.6979	-2.5399	0.4433	-1.8380	-1.1485	.6995	-2.7819	-0.5710	-2.0214	-1.2779
.7805	-0.5162	-2.1177	-0.7985	-1.5081	.7747	-0.0367	-0.8587	-0.8318	-1.1661
.8500	0.5380	-0.8828	0.1689	-0.8554	.8964	0.1132	-0.0520	0.0163	-0.6724
.8996	0.3977	-0.4792	0.3968	-0.3780					
.9495	0.0547	-0.1119	0.4222	-0.0335					

y/s = 0.590					y/s = 0.698				
Upper		Lower			Upper		Lower		
x/c	Real	Imag	Real	Imag	x/c	Real	Imag	Real	Imag
.0767	-15.8569	6.4711	-0.3001	-0.5740	.0754	-9.1231	3.4473	-0.2362	-0.0153
.1271	-10.0087	3.7820	-2.6478	0.3064	.1237	-19.9762	7.3894	-2.7558	0.2266
.1993	-5.7552	1.4243	-2.7235	0.1523	.1980	-11.1473	4.5946	-3.2105	0.1402
.7802	-1.2814	0.0627	-0.2849	-0.7578	.2502	-2.8698	0.6362	-2.9644	0.0052
.8514	0.0110	-0.1990	0.0920	-0.3493	.3001	-0.8251	-0.1248	-1.5437	-0.0485
.9016	-0.1657	0.0863	0.4027	-0.4587	.3476	-1.1886	-0.6561	-3.2946	-0.2015
.9511	-0.3177	0.5065	0.3964	0.0417	.4495	-1.7625	-0.2571	-3.1597	-0.5856
					.4974	-2.2959	0.3924	-3.0858	-0.7522
					.5484	-1.9676	0.7123	-2.4403	-0.9416
					.6007	-2.0317	0.6798	-2.5797	-1.0950
					.6514	-3.5270	-1.8832	-2.0712	-1.2445
					.7000	-2.5524	-6.1016	-1.5056	-1.6780
					.7795	0.0789	-0.3141	-0.2744	-0.8013
					.8547	0.6232	-0.3654	0.2637	-0.7523
					.9033	0.3476	-0.2419	0.3712	-0.6486
					.9522	0.0818	-0.0301	0.5680	-0.4049

y/s = 0.856				
Upper		Lower		
x/c	Real	Imag	Real	Imag
.1955	-20.5156	5.5355	-3.3122	0.0809
.2458	-19.1505	5.0956	-3.1005	-0.0758
.2915	-16.4535	4.8425	-2.8078	-0.2013
.3454	-10.2510	3.1928	-3.0542	-0.2457
.4519	-4.9161	1.5973	-2.7798	-0.3561
.5497	1.5150	-4.3261	-2.1513	-0.6742
.6025	1.7298	-4.8578	-2.3689	-0.4092
.6545	-2.3071	0.7186	-1.4526	-1.1349
.7049	-1.4642	0.8763	-0.0176	-1.5319
.7808	0.0705	-0.0247		

(1-1) Tabulated data for test case 9E (point.90-D-29)
Figure 6. Continued.

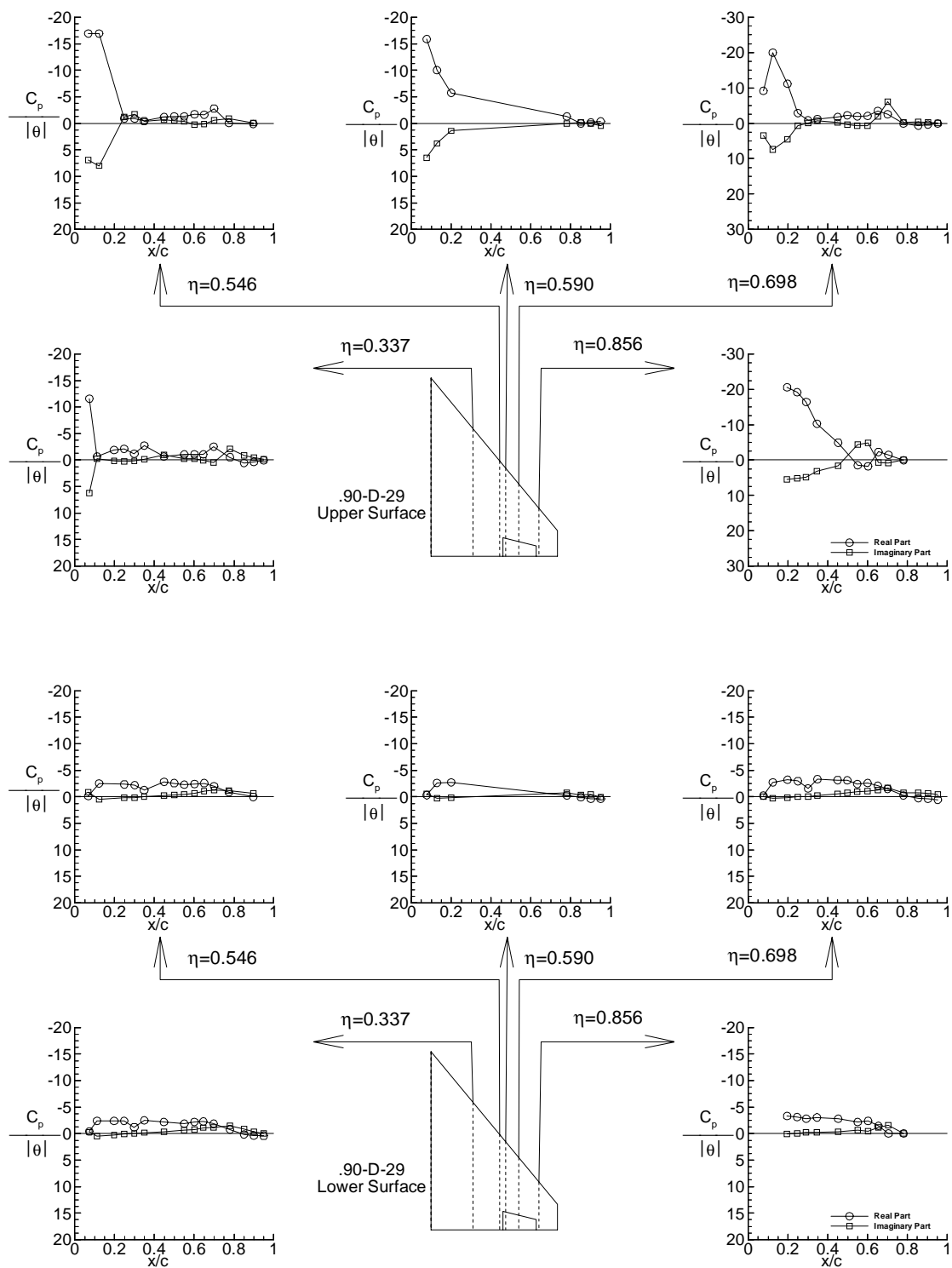

(1-2) Plot of data for test case 9E34 (point .90-D-29)
 Figure 6. Continued.

.40-D-32

MACH	q	To	H	ALPHAo	THETA	DELTA	RN
	psf	deg R	psf	deg	deg	deg	
0.405	84.9	547.8	1004.3	0.05	0.00	3.90	9.46*10**6

f = 7.99 Hz k = 0.376

y/s = 0.337					y/s = 0.546				
x/c	Upper		Lower		x/c	Upper		Lower	
	Real	Imag	Real	Imag		Real	Imag	Real	Imag
.0731	0.2898	-0.3475			.0681	0.6468	-0.3482		
.1120	-0.0215	0.0200			.1217	0.0428	-0.0104		
.1974	-0.0250	0.0205			.2485	-0.0653	0.0175		
.2478	-0.0324	0.0202			.3004	-0.0434	0.0181		
.2987	-0.0388	0.0210			.3481	-0.0879	0.0173		
.3486	-0.0392	0.0259			.4487	-0.1261	0.0211		
.4477	-0.0416	0.0185			.4997	-0.1151	0.0147		
.5506	-0.0606	0.0117			.5500	-0.1378	0.0089		
.6009	-0.0854	0.0146			.6014	-0.1792	0.0053		
.6459	-0.0803	0.0178			.6494	-0.2307	0.0000		
.6979	-0.0784	0.0123			.6995	-0.2585	-0.0059		
.7805	-0.0791	0.0061			.7747	-0.3623	-0.0209		
.8500	-0.0806	0.0052			.8964	-0.2062	-0.0533		
.8996	-0.0673	0.0060							
.9495	-0.0393	0.0056							

y/s = 0.590					y/s = 0.698				
x/c	Upper		Lower		x/c	Upper		Lower	
	Real	Imag	Real	Imag		Real	Imag	Real	Imag
.0767	-0.8055	0.0408			.0754	0.0864	-0.5590		
.1271	-0.0594	0.0291			.1237	-0.0787	0.0362		
.1993	-0.0699	0.0269			.1980	-0.1024	0.0317		
.7802	-0.8175	-0.0357			.2502	-0.1128	0.0273		
.8514	-0.6488	-0.1191			.3001	-0.1299	0.0245		
.9016	-0.3240	-0.1463			.3476	-0.1624	0.0263		
.9511	0.0097	-0.0906			.4495	-0.1989	0.0185		
					.4974	-0.2434	0.0157		
					.5484	-0.2600	-0.0064		
					.6007	-0.3614	0.0038		
					.6514	-0.4686	-0.0057		
					.7000	-0.6608	-0.0196		
					.7795	-1.1513	-0.0886		
					.8547	-0.9503	-0.1420		
					.9033	-0.4788	-0.1473		
					.9522	-0.1406	-0.1063		

y/s = 0.856				
x/c	Upper		Lower	
	Real	Imag	Real	Imag
.1955	-0.1698	0.0352		
.2458	-0.1928	0.0399		
.2915	-0.1982	0.0350		
.3454	-0.2256	0.0313		
.4519	-0.2535	0.0177		
.5497	-0.2849	0.0080		
.6025	-0.3320	0.0017		
.6545	-0.3820	-0.0027		
.7049	-0.4039	-0.0099		
.7808	0.0000	0.0000		

(m-1) Tabulated data for test case 9E35 (point.40-D-32)
Figure 6. Continued.

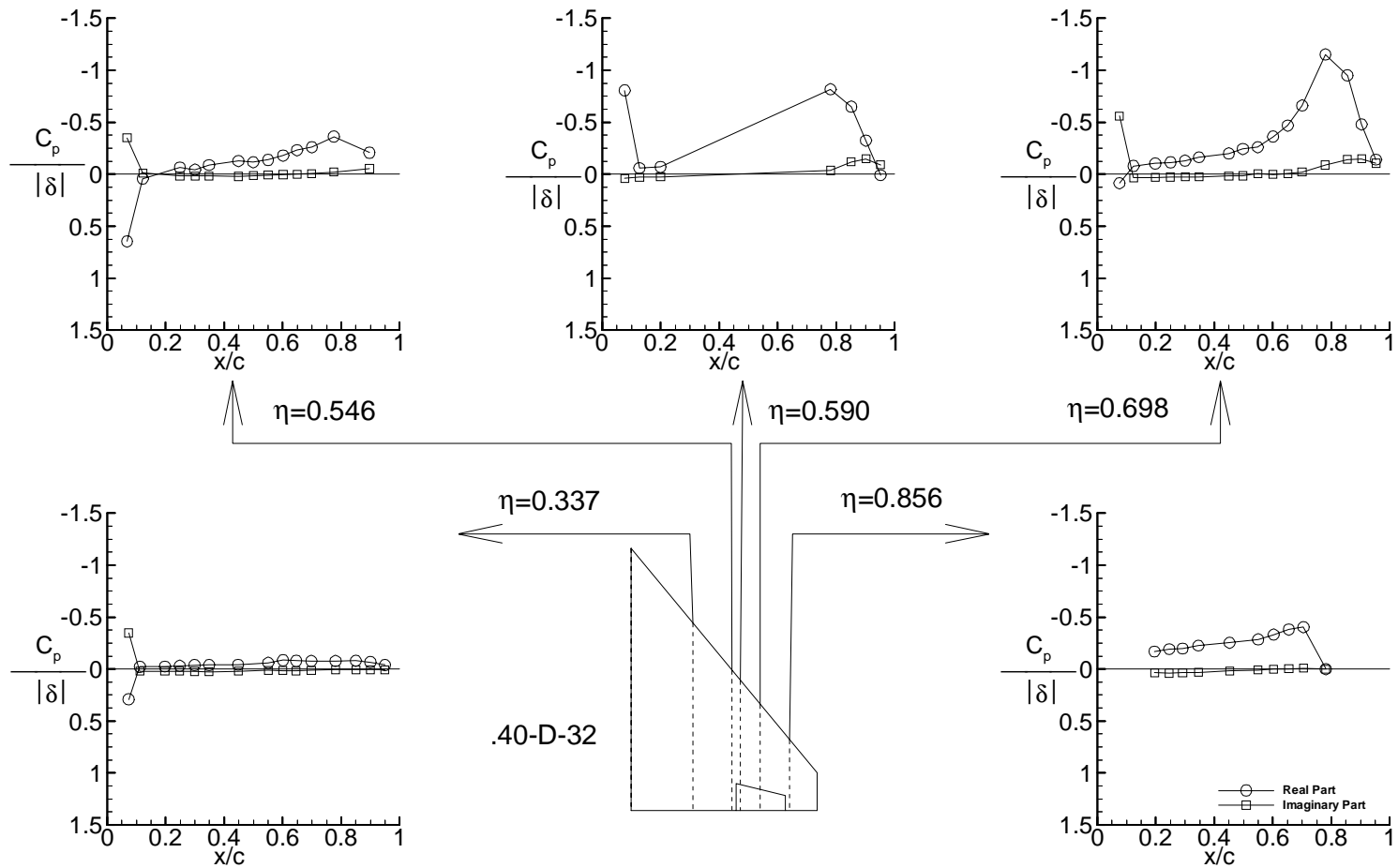

(m-2) Plot of data for test case 9E35 (point.40-D-32)
Figure 6. Continued.

.88-D-34

MACH	q	To	H	ALPHAo	THETA	DELTA	RN
	psf	deg R	psf	deg	deg	deg	
0.878	182.1	554.5	638.1	0.05	0.00	3.88	9.77*10**6

f = 16.00 Hz k = 0.350

y/s = 0.337					y/s = 0.546				
x/c	Upper		Lower		x/c	Upper		Lower	
	Real	Imag	Real	Imag		Real	Imag	Real	Imag
.0731	-0.0140	-0.0082			.0681	-0.0283	-0.0745		
.1120	-0.0014	-0.0004			.1217	0.0012	-0.0009		
.1974	-0.0182	-0.0321			.2485	0.0836	-0.1033		
.2478	-0.0067	-0.0453			.3004	0.1578	-0.1119		
.2987	0.0067	-0.0512			.3481	0.1653	-0.0822		
.3486	0.0359	-0.0842			.4487	0.3089	0.0506		
.4477	0.1200	-0.0808			.4997	0.2857	0.1696		
.5506	0.1844	0.0344			.5500	0.2204	0.2962		
.6009	0.2166	0.1462			.6014	0.1180	0.5017		
.6459	0.1852	0.3497			.6494	-0.2142	0.7374		
.6979	-0.0123	0.4384			.6995	-0.5866	0.5745		
.7805	-0.3896	0.3000			.7747	-0.9393	0.1826		
.8500	-0.3237	0.0272			.8964	-0.3668	-0.1364		
.8996	-0.2015	-0.0305							
.9495	-0.0657	-0.0336							

y/s = 0.590					y/s = 0.698				
x/c	Upper		Lower		x/c	Upper		Lower	
	Real	Imag	Real	Imag		Real	Imag	Real	Imag
.0767	0.0005	-0.0694			.0754	-0.0013	0.0007		
.1271	-0.0014	-0.0003			.1237	-0.0017	-0.0056		
.1993	0.0760	-0.0633			.1980	0.1167	-0.0751		
.7802	-1.4051	0.0786			.2502	0.1436	-0.0456		
.8514	-1.0498	-0.2637			.3001	0.1713	0.0002		
.9016	-0.3201	-0.3190			.3476	0.2341	0.0619		
.9511	0.2211	-0.2089			.4495	0.2183	0.2640		
					.4974	0.0825	0.3401		
					.5484	0.0221	0.4528		
					.6007	-0.2711	0.5709		
					.6514	-0.7204	0.6002		
					.7000	-1.3676	0.5332		
					.7795	-1.8857	-0.0132		
					.8547	-1.2584	-0.3184		
					.9033	-0.3609	-0.3028		
					.9522	0.1696	-0.2180		

y/s = 0.856				
x/c	Upper		Lower	
	Real	Imag	Real	Imag
.1955	0.1752	0.1495		
.2458	0.1916	0.2070		
.2915	0.1319	0.2308		
.3454	0.0693	0.3098		
.4519	-0.1690	0.3725		
.5497	-0.6030	0.4413		
.6025	0.0000	0.0000		
.6545	-1.1471	0.1673		
.7049	-1.1766	-0.0288		
.7808	0.0000	0.0000		

(n-1) Tabulated data for test case 9E36 (point.88-D-34)
Figure 6. Continued.

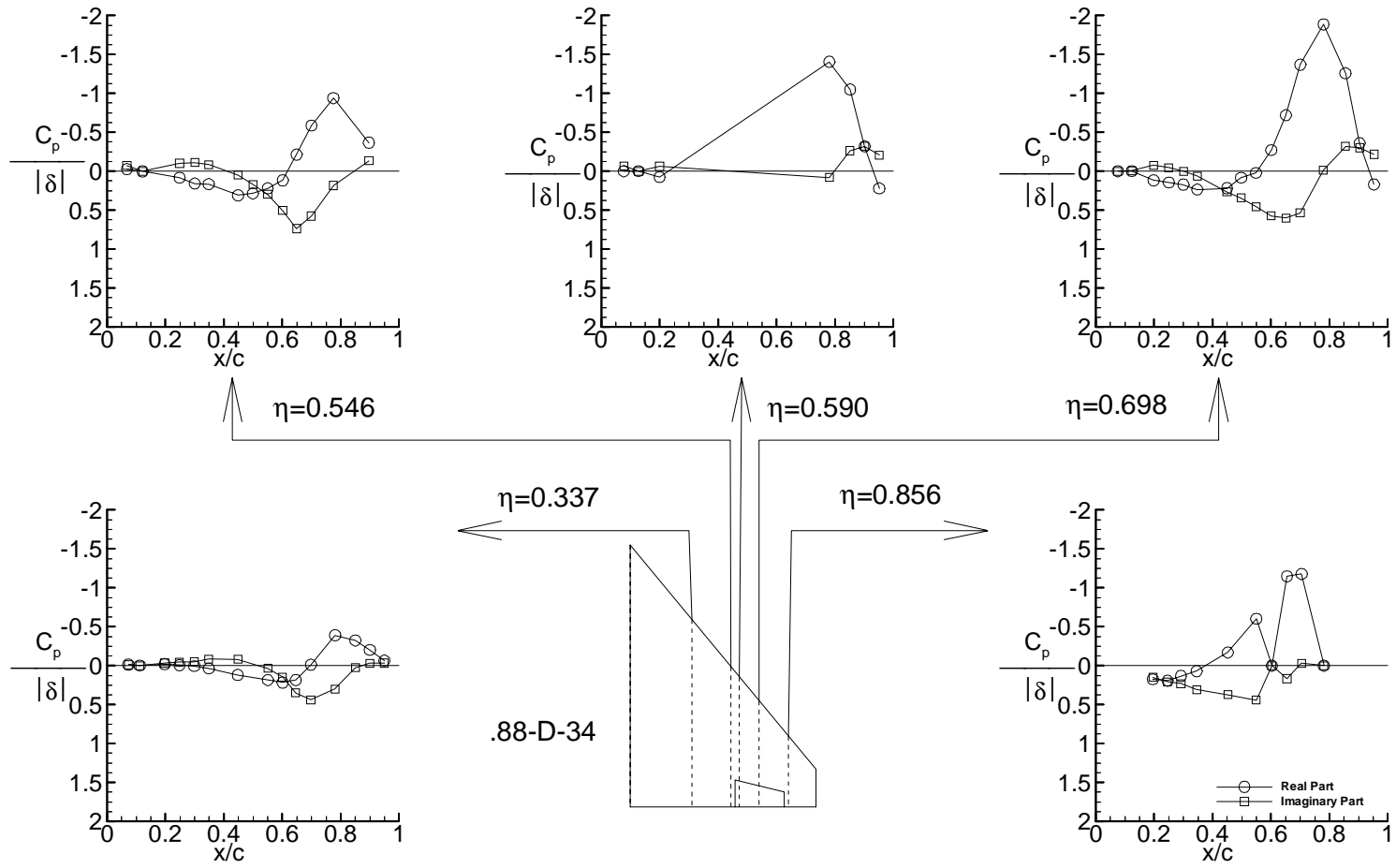

(n-2) Plot of data for test case 9E36 (point.88-D-34)
Figure 6. Continued.

.90-D-35

MACH	q	To	H	ALPHAo	THETA	DELTA	RN
	psf	deg R	psf	deg	deg	deg	
0.901	192.0	565.2	654.1	0.05	0.00	4.00	9.84*10**6

f = 16.00 Hz k = 0.338

y/s = 0.337					y/s = 0.546				
Upper			Lower		Upper			Lower	
x/c	Real	Imag	Real	Imag	x/c	Real	Imag	Real	Imag
.0731	-0.3013	0.0483			.0681	-0.1346	0.0014		
.1120	-0.2954	0.0389			.1217	-0.3132	0.0346		
.1974	-0.2567	0.0238			.2485	-0.2704	0.0128		
.2478	-0.2545	0.0151			.3004	-0.2546	0.0142		
.2987	-0.0003	0.0014			.3481	-0.0008	0.0012		
.3486	-0.2807	0.0059			.4487	-0.4544	0.0703		
.4477	-0.2034	0.0025			.4997	-0.2319	0.0081		
.5506	-0.1782	-0.0175			.5500	-0.2116	-0.0122		
.6009	-0.2402	0.0139			.6014	-0.2879	-0.0030		
.6459	-0.3362	0.0563			.6494	-0.3553	-0.1293		
.6979	-0.2748	-0.0416			.6995	-0.2401	-0.1589		
.7805	0.0218	-0.1008			.7747	0.0796	-0.0610		
.8500	0.0343	-0.0304			.8964	0.0180	-0.0142		
.8996	0.0133	-0.0053							
.9495	-0.0012	0.0085							

y/s = 0.590					y/s = 0.698				
Upper			Lower		Upper			Lower	
x/c	Real	Imag	Real	Imag	x/c	Real	Imag	Real	Imag
.0767	-0.7556	0.1278			.0754	-0.2543	0.0182		
.1271	-0.5800	0.0825			.1237	-0.1991	0.0010		
.1993	-0.4027	0.0466			.1980	-0.2930	0.0195		
.7802	0.0688	-0.0562			.2502	-0.3981	0.0489		
.8514	-0.0005	0.0028			.3001	-0.0006	0.0013		
.9016	0.0258	-0.0002			.3476	-0.4392	0.0547		
.9511	0.0037	0.0123			.4495	-0.3093	0.0070		
					.4974	-0.3492	0.0140		
					.5484	-0.3953	0.0048		
					.6007	-0.4157	-0.0673		
					.6514	-0.3653	-0.2793		
					.7000	0.2386	-0.3260		
					.7795	0.0521	-0.0096		
					.8547	0.0902	0.0036		
					.9033	0.0968	-0.0106		
					.9522	-0.0052	0.0068		

y/s = 0.856				
Upper			Lower	
x/c	Real	Imag	Real	Imag
.1955	-0.2882	0.0252		
.2458	-0.4349	0.0220		
.2915	-0.3566	0.0056		
.3454	-0.4440	0.0008		
.4519	-0.4439	0.0108		
.5497	-0.3540	-0.2255		
.6025	0.2054	-0.2757		
.6545	0.4322	-0.1017		
.7049	0.1496	0.0151		
.7808	0.0026	0.0199		

(o-1) Tabulated data for test case 9E37 (point.90-D-35)
Figure 6. Continued.

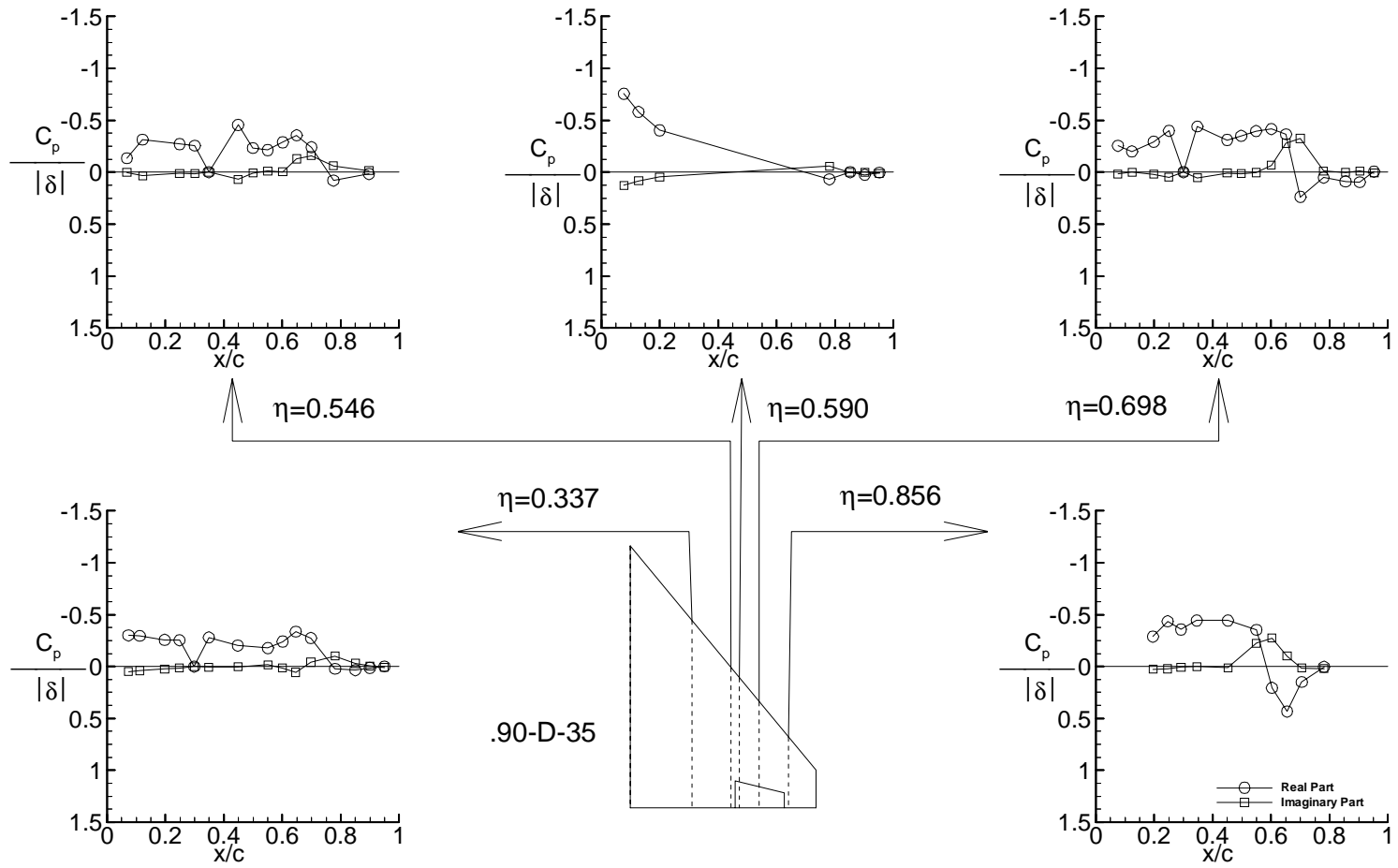

(o-2) Plot of data for test case 9E37 (point .90-D-35)
Figure 6. Continued.

.92-D-33

MACH	q	To	H	ALPHAo	THETA	DELTA	RN
	psf	deg R	psf	deg	deg	deg	
0.923	197.2	548.0	652.8	0.05	0.00	3.93	10.29*10**6

f = 15.98 Hz k = 0.337

y/s = 0.337					y/s = 0.546				
x/c	Upper		Lower		x/c	Upper		Lower	
	Real	Imag	Real	Imag		Real	Imag	Real	Imag
.0731	0.0204	0.0165			.0681	0.0393	-0.0023		
.1120	-0.0014	0.0002			.1217	0.0003	0.0014		
.1974	0.0167	0.0307			.2485	0.0211	0.0315		
.2478	0.0045	0.0376			.3004	0.0424	0.0284		
.2987	-0.0003	0.0423			.3481	-0.0006	0.0437		
.3486	0.0019	0.0393			.4487	-0.0073	0.0593		
.4477	-0.0069	0.0358			.4997	-0.0184	0.0331		
.5506	-0.0436	0.0266			.5500	-0.0449	0.0211		
.6009	-0.0754	0.0228			.6014	-0.0552	-0.0046		
.6459	-0.0842	0.0074			.6494	-0.0616	-0.0179		
.6979	-0.0798	-0.0357			.6995	-0.0711	-0.0458		
.7805	0.2272	-0.0645			.7747	-0.3536	0.9558		
.8500	-0.2878	0.3579			.8964	-0.3878	-0.0339		
.8996	-0.2581	0.0677							
.9495	-0.0912	-0.0109							

y/s = 0.590					y/s = 0.698				
x/c	Upper		Lower		x/c	Upper		Lower	
	Real	Imag	Real	Imag		Real	Imag	Real	Imag
.0767	0.0843	-0.0282			.0754	-0.0014	0.0004		
.1271	-0.0007	-0.0013			.1237	-0.0018	0.0071		
.1993	0.0379	0.0152			.1980	0.0260	0.0296		
.7802	-1.5885	1.3048			.2502	0.0125	0.0247		
.8514	-1.0553	-0.0239			.3001	0.0057	0.0286		
.9016	-0.3757	-0.2459			.3476	0.0073	0.0327		
.9511	0.1790	-0.2152			.4495	-0.0205	0.0139		
					.4974	-0.0328	0.0121		
					.5484	-0.0114	-0.0220		
					.6007	-0.0242	-0.0273		
					.6514	-0.0134	-0.0416		
					.7000	-0.0812	0.1841		
					.7795	-2.4117	1.0889		
					.8547	-1.3200	-0.3096		
					.9033	-0.3826	-0.3421		
					.9522	0.1716	-0.2932		

y/s = 0.856				
x/c	Upper		Lower	
	Real	Imag	Real	Imag
.1955	-0.0045	-0.0037		
.2458	-0.0193	-0.0131		
.2915	-0.0096	-0.0128		
.3454	-0.0026	-0.0349		
.4519	0.0072	-0.0490		
.5497	0.0349	-0.0624		
.6025	0.0429	-0.0534		
.6545	0.0104	0.0869		
.7049	-1.3154	1.9949		
.7808	0.0000	0.0000		

(p-1) Tabulated data for test case 9E38 (point.92-D-33)
Figure 6. Continued.

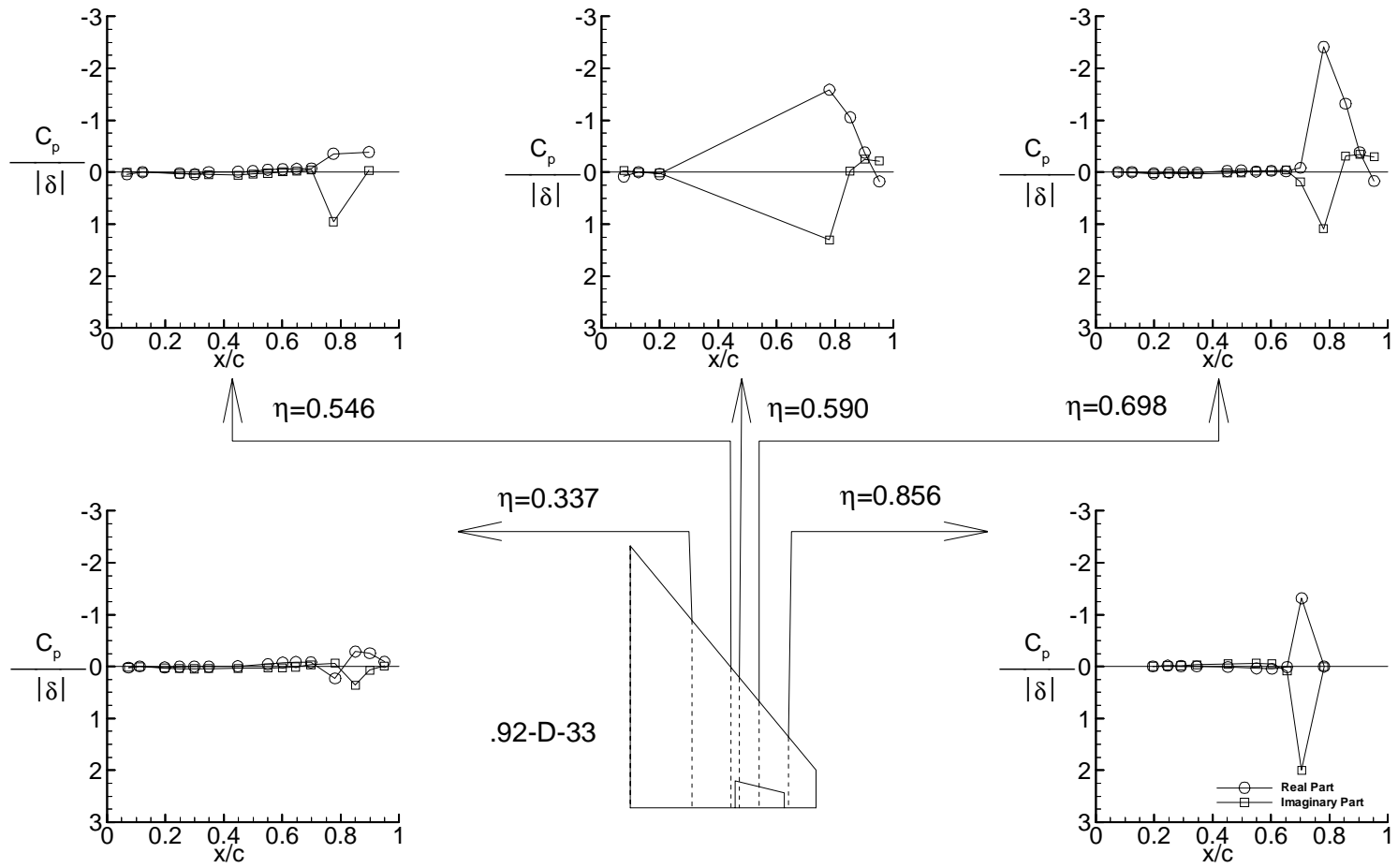

(p-2) Plot of data for test case 9E38 (point.92-D-33)
 Figure 6. Continued.

.94-D-34

MACH	q	To	H	ALPHAo	THETA	DELTA	RN
	psf	deg R	psf	deg	deg	deg	
0.942	203.4	561.3	659.1	0.05	0.00	3.96	10.06*10**6

f = 15.98 Hz k = 0.326

y/s = 0.337					y/s = 0.546				
x/c	Upper		Lower		x/c	Upper		Lower	
	Real	Imag	Real	Imag		Real	Imag	Real	Imag
.0731	0.0198	-0.0381			.0681	-0.0273	0.0232		
.1120	0.0017	-0.0039			.1217	0.0090	0.0044		
.1974	0.0071	-0.0006			.2485	0.0057	0.0007		
.2478	0.0057	-0.0008			.3004	0.0243	0.0021		
.2987	0.0044	-0.0036			.3481	0.0044	-0.0057		
.3486	0.0079	-0.0034			.4487	0.0140	-0.0028		
.4477	0.0058	-0.0042			.4997	0.0167	-0.0040		
.5506	0.0054	-0.0067			.5500	0.0155	-0.0025		
.6009	0.0009	-0.0100			.6014	0.0257	-0.0014		
.6459	0.0204	-0.0104			.6494	0.0276	0.0076		
.6979	0.0224	-0.0155			.6995	0.0306	0.0157		
.7805	0.0411	-0.0057			.7747	0.0255	0.0272		
.8500	-0.2525	0.5806			.8964	-0.3824	-0.0476		
.8996	-0.2073	0.0277							
.9495	-0.0652	-0.0329							

y/s = 0.590					y/s = 0.698				
x/c	Upper		Lower		x/c	Upper		Lower	
	Real	Imag	Real	Imag		Real	Imag	Real	Imag
.0767	0.0195	-0.0048			.0754	-0.0203	-0.0159		
.1271	0.0016	0.0023			.1237	0.0013	-0.0056		
.1993	0.0016	0.0023			.1980	0.0071	-0.0048		
.7802	-0.2014	0.0826			.2502	0.0083	-0.0079		
.8514	-0.9311	-0.0032			.3001	0.0097	-0.0061		
.9016	-0.4574	-0.2221			.3476	0.0141	-0.0070		
.9511	0.0182	-0.1983			.4495	0.0195	-0.0045		
					.4974	0.0214	0.0016		
					.5484	0.0301	0.0093		
					.6007	0.0220	0.0134		
					.6514	0.0230	0.0194		
					.7000	0.0181	0.0240		
					.7795	-1.1054	0.3380		
					.8547	-1.0257	-0.3937		
					.9033	-0.3794	-0.3298		
					.9522	0.0323	-0.3120		

y/s = 0.856				
x/c	Upper		Lower	
	Real	Imag	Real	Imag
.1955	0.0183	0.0034		
.2458	0.0178	0.0053		
.2915	0.0282	0.0104		
.3454	0.0286	0.0132		
.4519	0.0206	0.0178		
.5497	0.0173	0.0263		
.6025	0.0077	0.0246		
.6545	-0.0013	0.0286		
.7049	-0.0027	0.0271		
.7808	0.0000	0.0000		

(q-1) Tabulated data for test case 9E39 (point.94-D-34)
Figure 6. Continued.

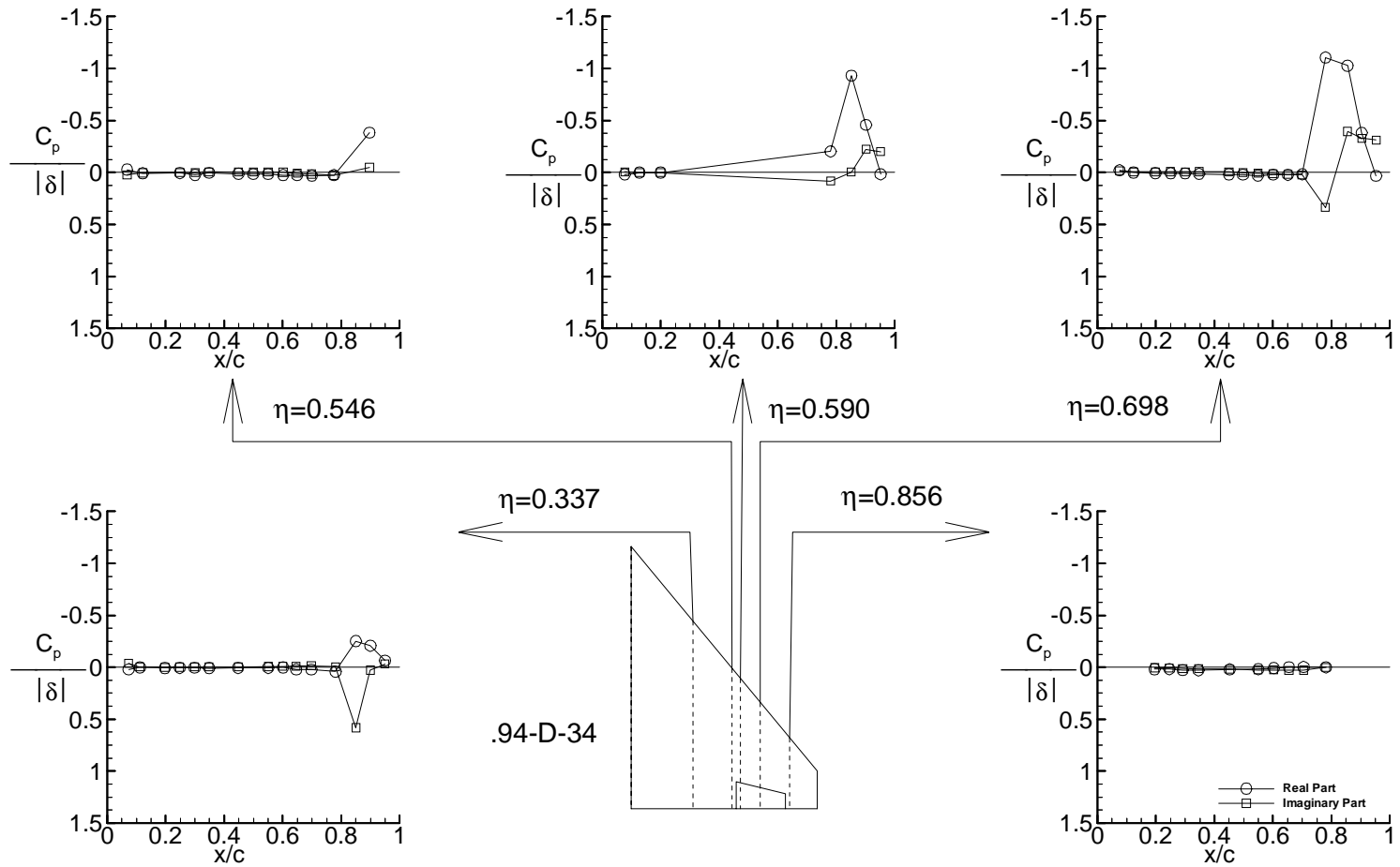

(q-2) Plot of data for test case 9E39 (point.94-D-34)
Figure 6. Continued.

.96-D-10

MACH	q	To	H	ALPHAo	THETA	DELTA	RN
	psf	deg R	psf	deg	deg	deg	
0.960	200.6	569.3	638.1	0.05	0.00	4.54	9.59*10**6

f = 16.00 Hz k = 0.315

y/s = 0.337					y/s = 0.546				
Upper			Lower		Upper			Lower	
x/c	Real	Imag	Real	Imag	x/c	Real	Imag	Real	Imag
.0731	0.0033	0.0019			.0681	-0.0008	-0.0024		
.1120	-0.0020	0.0046			.1217	-0.0113	0.0009		
.1974	-0.0046	0.0043			.2485	0.0003	-0.0025		
.2478	-0.0037	0.0035			.3004	-0.0003	0.0114		
.2987	-0.0020	0.0015			.3481	0.0002	-0.0025		
.3486	-0.0052	0.0055			.4487	0.0006	0.0011		
.4477	-0.0025	0.0003			.4997	0.0032	0.0039		
.5506	-0.0028	-0.0042			.5500	0.0012	0.0004		
.6009	0.0003	-0.0088			.6014	0.0019	0.0017		
.6459	0.0014	0.0021			.6494	0.0011	0.0006		
.6979	0.0025	-0.0004			.6995	0.0012	0.0062		
.7805	0.0044	0.0061			.7747	0.0017	0.0061		
.8500	0.0056	0.0068			.8964	-0.2912	-0.1935		
.8996	-0.3328	0.2220							
.9495	-0.0555	-0.0026							

y/s = 0.590					y/s = 0.698				
Upper			Lower		Upper			Lower	
x/c	Real	Imag	Real	Imag	x/c	Real	Imag	Real	Imag
.0767	-0.0050	-0.0007			.0754	0.0058	0.0067		
.1271	-0.0038	0.0001			.1237	0.0035	0.0052		
.1993	-0.0007	-0.0024			.1980	0.0006	0.0063		
.7802	-0.0802	0.0305			.2502	0.0016	0.0074		
.8514	-0.7036	0.1496			.3001	0.0003	0.0025		
.9016	0.4681	-0.9031			.3476	0.0001	0.0088		
.9511	-0.1500	-0.3338			.4495	0.0016	0.0074		
					.4974	0.0025	0.0044		
					.5484	-0.0002	0.0088		
					.6007	-0.0011	0.0049		
					.6514	-0.0013	0.0049		
					.7000	-0.0021	0.0046		
					.7795	-0.5026	0.2113		
					.8547	-0.3777	-0.2315		
					.9033	1.0289	-1.8046		
					.9522	0.0000	0.0000		

y/s = 0.856				
Upper			Lower	
x/c	Real	Imag	Real	Imag
.1955	-0.0015	0.0048		
.2458	0.0003	0.0012		
.2915	-0.0005	0.0050		
.3454	0.0007	0.0113		
.4519	0.0008	0.0063		
.5497	0.0000	0.0000		
.6025	0.0024	0.0044		
.6545	-0.0013	0.0075		
.7049	-0.0043	0.0105		
.7808	-0.0056	0.0030		

(r-1) Tabulated data for test case 9E40 (point.96-D-10)
Figure 6. Continued.

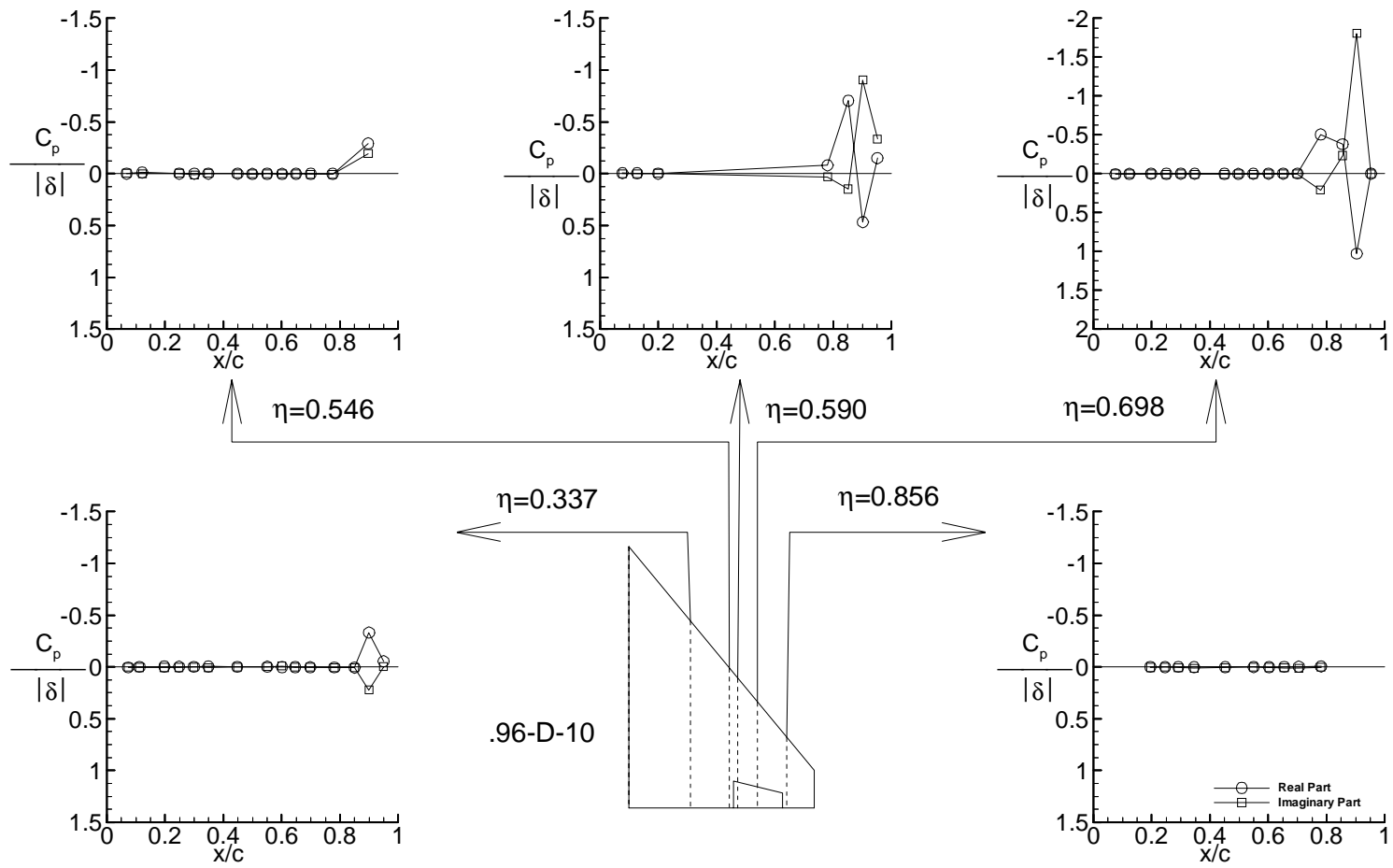

(r-2) Plot of data for test case 9E40 (point .96-D-10)
Figure 6. Continued.

1.12-D-11

MACH	q	To	H	ALPHAo	THETA	DELTA	RN
	psf	deg R	psf	deg	deg	deg	
1.120	231.7	572.5	643.8	0.00	0.00	4.37	9.76*10**6

f = 16.01 Hz k = 0.273

y/s = 0.337					y/s = 0.546				
Upper			Lower		Upper			Lower	
x/c	Real	Imag	Real	Imag	x/c	Real	Imag	Real	Imag
.0731	0.0004	-0.0079			.0681	0.0030	0.0087		
.1120	0.0049	-0.0061			.1217	0.0057	0.0033		
.1974	-0.0007	-0.0052			.2485	0.0026	0.0005		
.2478	-0.0030	0.0025			.3004	0.0179	-0.0039		
.2987	0.0010	0.0052			.3481	-0.0013	-0.0001		
.3486	0.0000	0.0000			.4487	0.0000	0.0000		
.4477	0.0118	0.0005			.4997	0.0073	0.0056		
.5506	0.0092	0.0004			.5500	0.0029	0.0026		
.6009	0.0050	-0.0017			.6014	0.0066	-0.0002		
.6459	0.0129	0.0025			.6494	0.0079	-0.0003		
.6979	0.0046	0.0026			.6995	0.0103	0.0018		
.7805	0.0104	-0.0012			.7747	0.0075	0.0024		
.8500	-0.0023	-0.0032			.8964	-0.2583	0.0027		
.8996	-0.0035	0.0018							
.9495	0.0006	-0.0025							

y/s = 0.590					y/s = 0.698				
Upper			Lower		Upper			Lower	
x/c	Real	Imag	Real	Imag	x/c	Real	Imag	Real	Imag
.0767	-0.0009	0.0025			.0754	0.0039	-0.0006		
.1271	0.0039	-0.0002			.1237	0.0038	0.0010		
.1993	0.0104	-0.0014			.1980	0.0067	-0.0041		
.7802	0.0009	0.0009			.2502	0.0064	-0.0045		
.8514	-0.3985	-0.0070			.3001	0.0039	-0.0006		
.9016	-0.0010	0.0009			.3476	0.0090	-0.0019		
.9511	-0.4660	-0.0261			.4495	0.0105	0.0004		
					.4974	0.0076	0.0019		
					.5484	0.0104	-0.0017		
					.6007	0.0046	-0.0025		
					.6514	0.0065	-0.0010		
					.7000	0.0039	-0.0007		
					.7795	-0.0222	0.0021		
					.8547	-1.2507	0.0131		
					.9033	-1.2350	0.0108		
					.9522	-1.1970	0.0063		

y/s = 0.856				
Upper			Lower	
x/c	Real	Imag	Real	Imag
.1955	0.0052	0.0008		
.2458	0.0091	-0.0009		
.2915	0.0105	0.0008		
.3454	0.0117	0.0011		
.4519	0.0079	0.0004		
.5497	0.0052	-0.0003		
.6025	0.0051	0.0014		
.6545	0.0065	0.0009		
.7049	0.0092	0.0002		
.7808	0.0008	-0.0010		

(s-1) Tabulated data for test case 9E41 (point 1.12-D-11)
Figure 6. Continued.

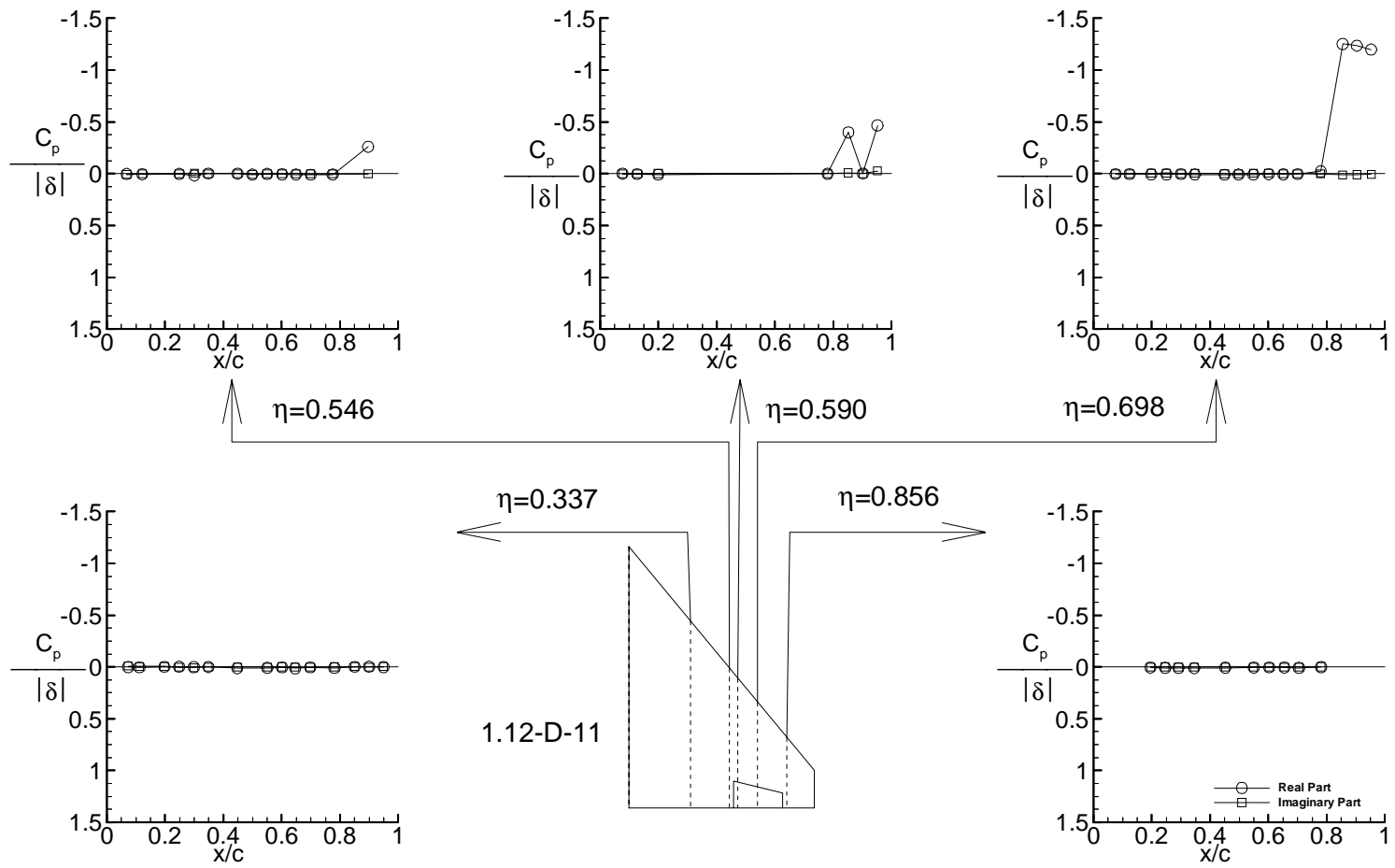

(s-2) Plot of data for test case 9E41 (point 1.12-D-11)
 Figure 6. Continued.

.90-D-32

MACH	q	To	H	ALPHAo	THETA	DELTA	RN
	psf	deg R	psf	deg	deg	deg	
0.898	190.9	563.9	652.4	0.05	0.00	3.48	9.81*10**6

f = 7.99 Hz k = 0.170

y/s = 0.337					y/s = 0.546				
x/c	Upper		Lower		x/c	Upper		Lower	
	Real	Imag	Real	Imag		Real	Imag	Real	Imag
.0731	-0.3800	0.1862			.0681	-0.2389	0.0264		
.1120	-0.3899	0.1512			.1217	-0.4409	0.1099		
.1974	-0.3567	0.0719			.2485	-0.3847	0.0215		
.2478	-0.3654	0.0358			.3004	-0.4528	0.0669		
.2987	0.0000	0.0000			.3481	-0.0013	0.0010		
.3486	-0.4029	-0.0552			.4487	-0.4857	0.0034		
.4477	-0.3154	-0.0682			.4997	-0.3350	-0.0240		
.5506	-0.2580	-0.1085			.5500	-0.2457	-0.0856		
.6009	-0.2129	-0.1151			.6014	-0.3175	-0.0139		
.6459	-0.2006	0.0095			.6494	-0.3643	0.0577		
.6979	-0.1408	0.0558			.6995	-0.9266	0.4203		
.7805	-0.7221	-0.1028			.7747	-0.2578	-0.4595		
.8500	-0.0935	-0.3465			.8964	0.0624	-0.2064		
.8996	0.0246	-0.2242							
.9495	0.0247	-0.0905							

y/s = 0.590					y/s = 0.698				
x/c	Upper		Lower		x/c	Upper		Lower	
	Real	Imag	Real	Imag		Real	Imag	Real	Imag
.0767	-0.9296	0.4675			.0754	-0.4464	0.0851		
.1271	-0.7527	0.2904			.1237	-0.3361	-0.0312		
.1993	-0.5449	0.1208			.1980	-0.3833	-0.0161		
.7802	-0.2280	-0.3855			.2502	-0.4615	0.0640		
.8514	-0.0006	0.0015			.3001	0.0000	0.0000		
.9016	0.0759	-0.1535			.3476	-0.4957	0.0390		
.9511	0.1118	-0.0340			.4495	-0.3871	0.0339		
					.4974	-0.2989	-0.0740		
					.5484	-0.3090	0.0489		
					.6007	-0.2641	0.0371		
					.6514	-0.6639	0.4378		
					.7000	-1.3615	0.2523		
					.7795	-0.2242	-0.2653		
					.8547	-0.0039	-0.2272		
					.9033	0.0811	-0.1927		
					.9522	0.0490	-0.0415		

y/s = 0.856				
x/c	Upper		Lower	
	Real	Imag	Real	Imag
.1955	-0.2734	0.0857		
.2458	-0.4501	0.1737		
.2915	-0.3477	0.0822		
.3454	-0.4809	0.1760		
.4519	-0.3485	0.1255		
.5497	-0.8208	0.4550		
.6025	-1.6954	0.3295		
.6545	-0.3330	-0.9510		
.7049	0.2490	-0.7048		
.7808	0.0270	-0.2107		

(t-1) Tabulated data for test case 9E42 (point.90-D-32)
Figure 6. Continued.

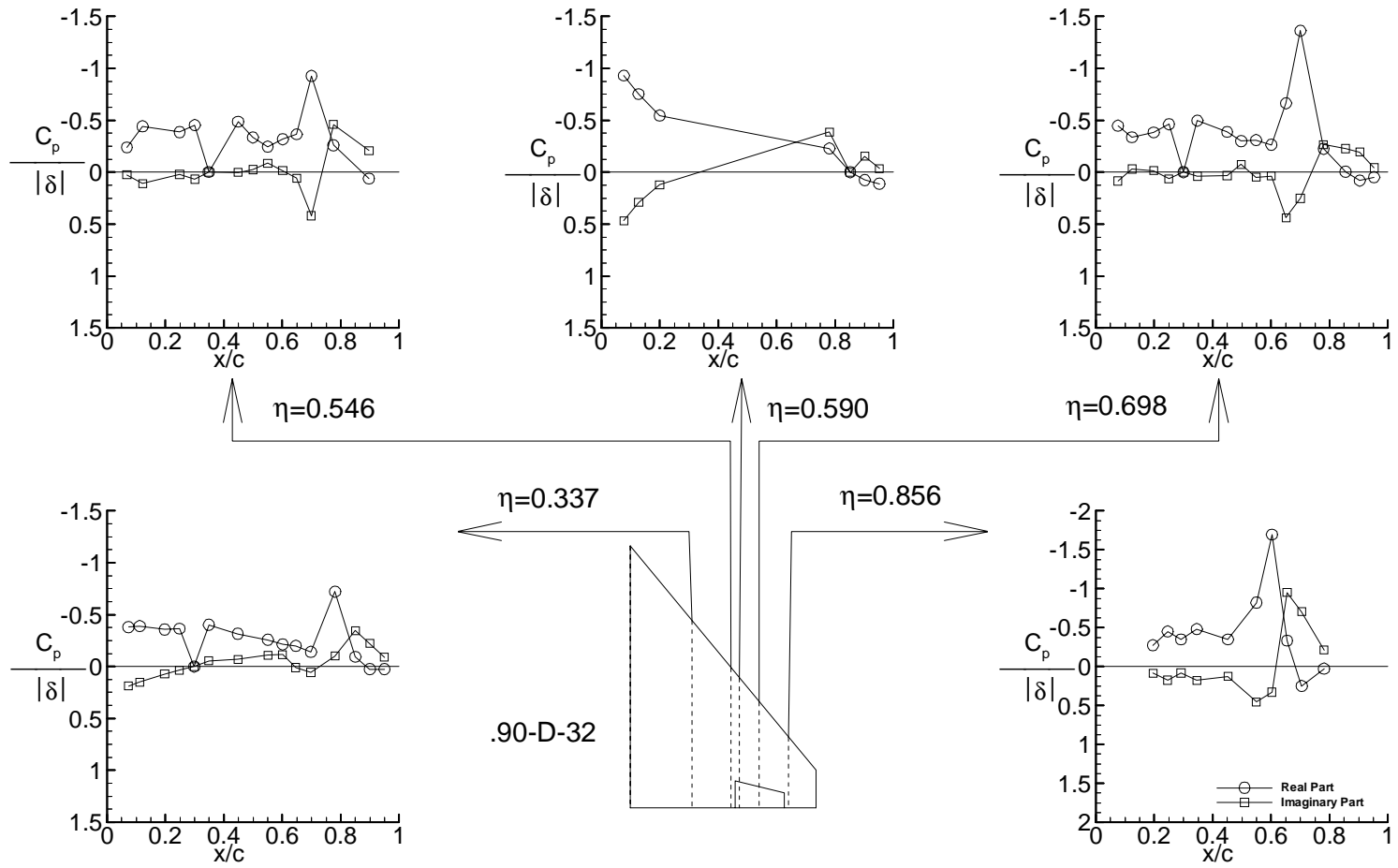

(t-2) Plot of data for test case 9E42 (point .90-D-32)
 Figure 6. Continued.

.92-D-36

MACH	q	To	H	ALPHAo	THETA	DELTA	RN
	psf	deg R	psf	deg	deg	deg	
0.924	197.6	551.8	653.9	0.05	0.00	3.89	10.25*10**6

f = 22.00 Hz k = 0.459

y/s = 0.337					y/s = 0.546				
x/c	Upper		Lower		x/c	Upper		Lower	
	Real	Imag	Real	Imag		Real	Imag	Real	Imag
.0731	0.0150	-0.0236			.0681	0.0222	0.0465		
.1120	0.0002	0.0015			.1217	0.0017	0.0024		
.1974	0.0462	0.0091			.2485	-0.0305	0.0207		
.2478	0.0415	0.0306			.3004	-0.0050	-0.0090		
.2987	0.0326	0.0509			.3481	-0.0474	-0.0163		
.3486	0.0275	0.0587			.4487	-0.0320	-0.0563		
.4477	-0.0133	0.0559			.4997	0.0003	-0.0574		
.5506	-0.0631	0.0148			.5500	0.0213	-0.0612		
.6009	-0.0912	-0.0053			.6014	0.0599	-0.0477		
.6459	-0.0681	-0.0382			.6494	0.0662	-0.0203		
.6979	-0.0164	-0.0793			.6995	0.0810	-0.0017		
.7805	0.1556	-0.0333			.7747	-0.3071	0.9177		
.8500	-0.1618	0.3584			.8964	-0.3891	-0.0306		
.8996	-0.2386	0.1123							
.9495	-0.1014	0.0074							

y/s = 0.590					y/s = 0.698				
x/c	Upper		Lower		x/c	Upper		Lower	
	Real	Imag	Real	Imag		Real	Imag	Real	Imag
.0767	0.0718	0.0699			.0754	0.0000	0.0000		
.1271	-0.0011	0.0010			.1237	0.0142	0.0038		
.1993	-0.0171	0.0275			.1980	-0.0197	0.0101		
.7802	-1.4898	1.3892			.2502	-0.0161	-0.0019		
.8514	-1.0898	-0.0190			.3001	-0.0185	-0.0050		
.9016	-0.4394	-0.2942			.3476	-0.0142	-0.0241		
.9511	0.1341	-0.2639			.4495	0.0135	-0.0358		
					.4974	0.0141	-0.0292		
					.5484	0.0452	-0.0247		
					.6007	0.0289	-0.0056		
					.6514	0.0251	0.0086		
					.7000	0.0074	0.0346		
					.7795	-2.7512	1.5502		
					.8547	-1.3259	-0.2649		
					.9033	-0.4606	-0.3906		
					.9522	0.1102	-0.3467		

y/s = 0.856				
x/c	Upper		Lower	
	Real	Imag	Real	Imag
.1955	0.0195	-0.0067		
.2458	0.0378	-0.0124		
.2915	0.0583	-0.0284		
.3454	0.0631	0.0057		
.4519	0.0383	0.0008		
.5497	0.0233	0.0126		
.6025	0.0014	0.0147		
.6545	-0.0150	0.0916		
.7049	-0.9545	1.6870		
.7808	0.0000	0.0000		

(u-1) Tabulated data for test case 9E43 (point .92-D-36)
Figure 6. Continued.

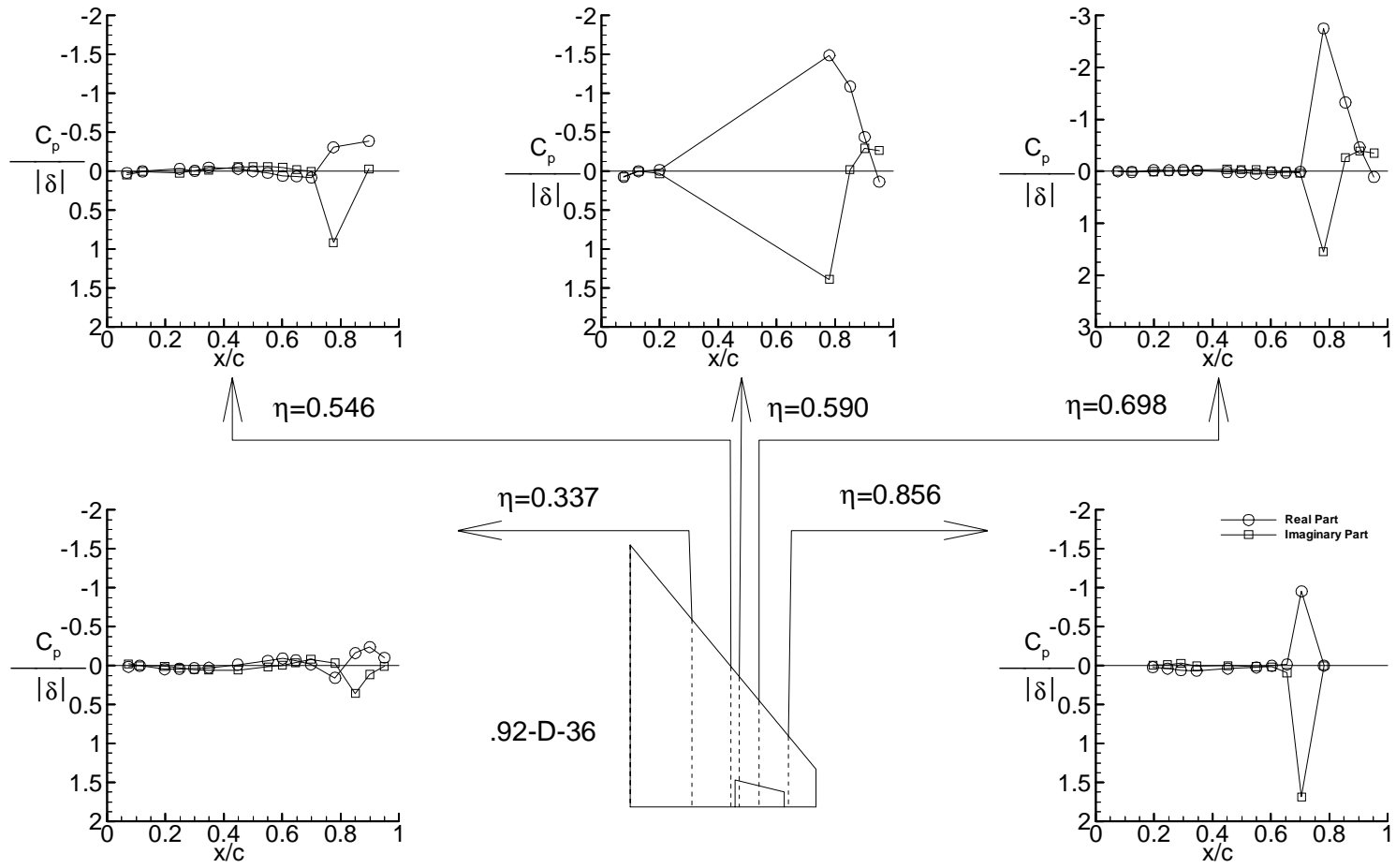

(u-2) Plot of data for test case 9E43 (point.92-D-36)
Figure 6. Continued.

.90-D-34

MACH	q	To	H	ALPHAo	THETA	DELTA	RN
	psf	deg R	psf	deg	deg	deg	
0.898	191.0	564.2	652.9	0.05	0.00	1.97	9.81*10**6

f = 16.00 Hz k = 0.339

y/s = 0.337					y/s = 0.546				
x/c	Upper		Lower		x/c	Upper		Lower	
	Real	Imag	Real	Imag		Real	Imag	Real	Imag
.0731	-0.3013	0.0499			.0681	-0.1794	0.0182		
.1120	-0.2913	0.0378			.1217	-0.3432	0.0446		
.1974	-0.2685	0.0330			.2485	-0.2959	0.0212		
.2478	-0.2741	0.0346			.3004	-0.2755	0.0207		
.2987	0.0000	0.0000			.3481	-0.0012	0.0026		
.3486	-0.2817	0.0153			.4487	-0.2966	-0.0052		
.4477	-0.1886	0.0135			.4997	-0.2409	0.0156		
.5506	-0.1547	-0.0273			.5500	-0.2472	0.0378		
.6009	-0.2113	0.0203			.6014	-0.2591	0.0373		
.6459	-0.3618	0.0743			.6494	-0.3418	0.0708		
.6979	-0.2843	-0.0199			.6995	-0.7041	0.0616		
.7805	0.0269	-0.1191			.7747	0.0795	-0.1321		
.8500	0.0034	-0.0435			.8964	-0.0226	0.0131		
.8996	0.0000	0.0000							
.9495	0.0144	0.0022							

y/s = 0.590					y/s = 0.698				
x/c	Upper		Lower		x/c	Upper		Lower	
	Real	Imag	Real	Imag		Real	Imag	Real	Imag
.0767	-0.8285	0.1580			.0754	-0.3791	0.0378		
.1271	-0.6188	0.0903			.1237	-0.2641	0.0175		
.1993	-0.4433	0.0388			.1980	-0.3079	0.0151		
.7802	0.0306	-0.0562			.2502	-0.4083	0.0379		
.8514	-0.0005	-0.0029			.3001	-0.0025	0.0016		
.9016	0.0074	0.0047			.3476	-0.4359	0.0175		
.9511	-0.0326	0.0243			.4495	-0.4185	0.0521		
					.4974	-0.2814	0.0202		
					.5484	-0.3744	0.0236		
					.6007	-0.3606	-0.0006		
					.6514	-0.5240	-0.1345		
					.7000	-0.1937	-0.2435		
					.7795	0.1085	-0.0208		
					.8547	0.1410	-0.0208		
					.9033	0.1367	-0.0281		
					.9522	-0.0165	0.0164		

y/s = 0.856				
x/c	Upper		Lower	
	Real	Imag	Real	Imag
.1955	-0.3051	0.0445		
.2458	-0.4523	0.0628		
.2915	-0.4239	0.0558		
.3454	-0.3990	0.0433		
.4519	-0.3243	0.0307		
.5497	-0.5828	0.0459		
.6025	-0.4770	-0.3278		
.6545	0.3344	-0.2980		
.7049	0.2804	-0.0309		
.7808	0.0718	0.0442		

(v-1) Tabulated data for test case 9E44 (point.90-D-34)
Figure 6. Continued.

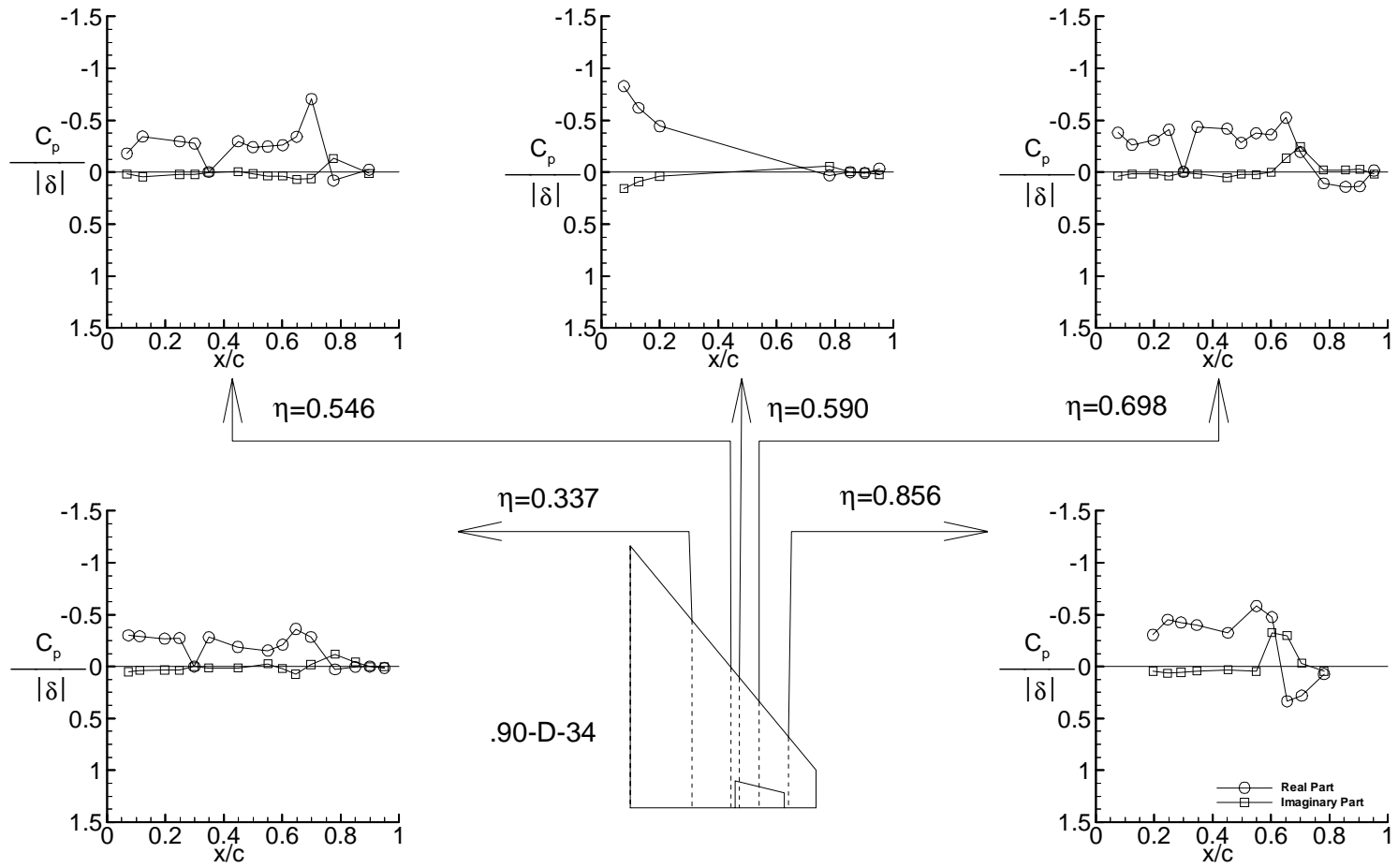

(v-2) Plot of data for test case 9E44 (point.90-D-34)
Figure 6. Continued.

.90-D-36

MACH	q	To	H	ALPHAo	THETA	DELTA	RN
	psf	deg R	psf	deg	deg	deg	
0.899	191.3	564.4	652.8	0.04	0.00	5.82	9.81*10**6

f = 16.01 Hz k = 0.340

y/s = 0.337					y/s = 0.546				
x/c	Upper		Lower		x/c	Upper		Lower	
	Real	Imag	Real	Imag		Real	Imag	Real	Imag
.0731	-0.0064	0.0020			.0681	-0.0062	0.0181		
.1120	-0.0057	0.0008			.1217	-0.0135	0.0174		
.1974	-0.0108	0.0037			.2485	-0.0294	0.0083		
.2478	-0.0198	0.0034			.3004	-0.0209	0.0025		
.2987	-0.0248	0.0018			.3481	-0.0647	-0.0127		
.3486	-0.0326	-0.0076			.4487	-0.0384	-0.0854		
.4477	-0.0533	-0.0419			.4997	-0.0458	-0.1266		
.5506	-0.0383	-0.1311			.5500	0.0094	-0.1726		
.6009	-0.0021	-0.2273			.6014	0.1847	-0.2446		
.6459	0.2323	-0.3257			.6494	0.5069	-0.0893		
.6979	0.5865	-0.0810			.6995	0.5067	0.6144		
.7805	0.0531	0.8903			.7747	-0.8897	0.8712		
.8500	-0.4548	0.2063			.8964	-0.3981	-0.1187		
.8996	-0.2845	0.0070							
.9495	-0.1065	-0.0269							

y/s = 0.590					y/s = 0.698				
x/c	Upper		Lower		x/c	Upper		Lower	
	Real	Imag	Real	Imag		Real	Imag	Real	Imag
.0767	-0.0186	0.0218			.0754	0.0000	0.0000		
.1271	-0.0183	0.0138			.1237	-0.0527	-0.0169		
.1993	-0.0317	0.0070			.1980	-0.0547	-0.0599		
.7802	-1.5484	0.7286			.2502	-0.0416	-0.0891		
.8514	-1.2725	-0.1743			.3001	-0.0246	-0.1119		
.9016	-0.4227	-0.3117			.3476	0.0070	-0.1622		
.9511	0.1215	-0.2143			.4495	0.1728	-0.2345		
					.4974	0.2554	-0.1233		
					.5484	0.4075	-0.0142		
					.6007	0.4828	0.3344		
					.6514	0.1288	0.9096		
					.7000	-0.9172	1.2764		
					.7795	-2.1792	0.5152		
					.8547	-1.5018	-0.4165		
					.9033	-0.3844	-0.3437		
					.9522	0.1408	-0.2733		

y/s = 0.856				
x/c	Upper		Lower	
	Real	Imag	Real	Imag
.1955	-0.0121	-0.0976		
.2458	0.0222	-0.1666		
.2915	0.0538	-0.1501		
.3454	0.1378	-0.1059		
.4519	0.2510	0.0235		
.5497	0.1170	0.5472		
.6025	0.0000	0.0000		
.6545	-1.1441	0.9331		
.7049	-1.6311	0.6957		
.7808	0.0000	0.0000		

(w-1) Tabulated data for test case 9E45 (point .90-D-36)
Figure 6. Continued.

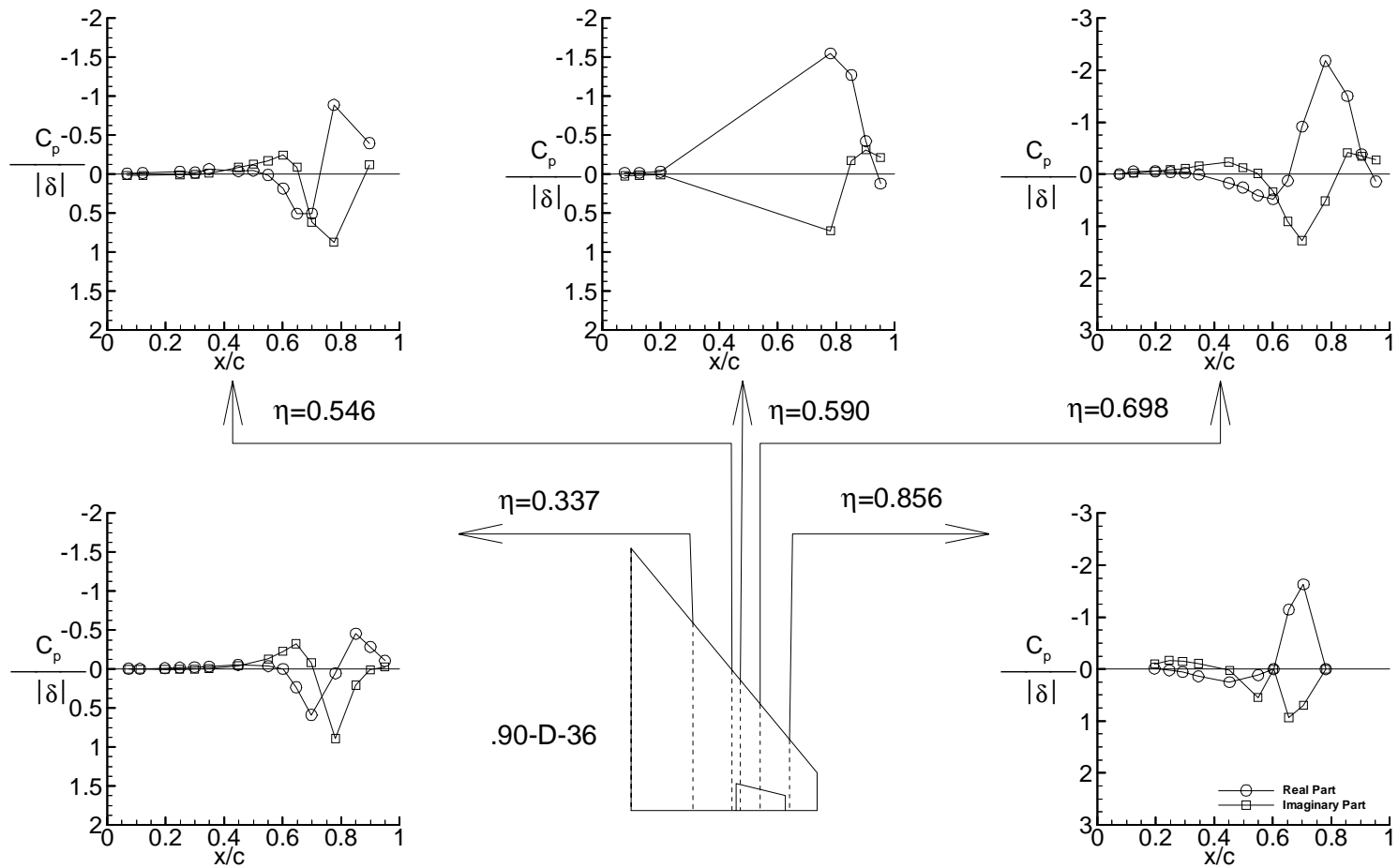

(w-2) Plot of data for test case 9E45 (point.90-D-36)
Figure 6. Continued.

.90-D-59

MACH	q psf	To deg R	H psf	ALPHAo deg	THETA deg	DELTA deg	RN
0.901	193.9	567.5	659.6	2.99	0.00	4.39	9.82*10**6

f = 16.01 Hz k = 0.337

y/s = 0.337					y/s = 0.546				
x/c	Upper		Lower		x/c	Upper		Lower	
	Real	Imag	Real	Imag		Real	Imag	Real	Imag
.0731	0.0268	-0.0103	-0.0043	-0.0049	.0681	-0.1342	0.0077	-0.0266	0.0322
.1120	0.0329	-0.0084	-0.0336	0.0649	.1217	0.0116	0.0234	-0.0617	-0.0169
.1974	0.0297	0.0045	-0.0643	0.0573	.2485	-0.0198	0.0243	-0.0620	-0.0774
.2478	0.0309	0.0106	-0.0908	0.0431	.3004	0.0050	0.0077	-0.0204	-0.1236
.2987	0.0000	0.0000	-0.0593	0.0096	.3481	0.0013	0.0001	-0.0146	-0.0783
.3486	0.0490	0.0215	-0.1462	-0.0198	.4487	-0.0403	-0.0241	0.1092	-0.2428
.4477	0.0045	0.0363	-0.1342	-0.1371	.4997	-0.0353	-0.0268	0.2006	-0.2127
.5506	-0.0242	0.0178	-0.0092	-0.2387	.5500	-0.0444	-0.0275	0.2901	-0.1435
.6009	-0.0546	0.0357	0.1081	-0.3175	.6014	-0.0416	-0.0552	0.4646	0.0050
.6459	-0.0373	-0.0063	0.3995	-0.3217	.6494	0.0051	-0.1108	0.5660	0.3769
.6979	-0.0049	-0.0349	0.6155	0.0474	.6995	0.4376	0.1600	0.1799	0.8184
.7805	0.0732	0.4244	0.0408	0.8304	.7747	-0.6342	0.5771	-0.9710	0.7370
.8500	-0.2399	0.1185	-0.4229	0.2277	.8964	-0.3976	-0.0194	-0.4507	-0.1327
.8996	-0.1595	0.0185	-0.2869	0.0408					
.9495	-0.0528	-0.0086	-0.1127	-0.0136					

y/s = 0.590					y/s = 0.698				
x/c	Upper		Lower		x/c	Upper		Lower	
	Real	Imag	Real	Imag		Real	Imag	Real	Imag
.0767	-0.0167	0.0340	0.0450	-0.0688	.0754	-0.1242	-0.0746	-0.0122	0.0800
.1271	-0.0213	0.0281	-0.0648	-0.0242	.1237	-0.1669	-0.0775	-0.0040	-0.0887
.1993	-0.0319	0.0270	-0.0664	-0.0608	.1980	-0.0375	0.0237	0.0376	-0.1209
.7802	-1.0761	0.3938	-1.5173	0.4697	.2502	-0.0438	0.0130	0.0760	-0.1279
.8514	-0.0008	0.0011	-0.6380	-0.1171	.3001	0.0000	0.0000	0.0665	-0.0664
.9016	-0.3943	-0.1633	-0.4121	-0.3373	.3476	-0.0723	-0.0109	0.2101	-0.1342
.9511	0.0113	-0.1077	0.1769	-0.2245	.4495	-0.0583	-0.0292	0.3650	0.0170
					.4974	-0.0430	-0.0508	0.3672	0.1360
					.5484	-0.0106	-0.0815	0.3440	0.3200
					.6007	0.0005	-0.0914	0.1920	0.5895
					.6514	0.0616	0.2362	-0.2381	0.7693
					.7000	-0.8134	1.6827	-1.0390	0.9621
					.7795	-1.4709	0.0874	-2.1305	0.2654
					.8547	-1.1195	-0.1974	-1.3946	-0.4424
					.9033	-0.4026	-0.2131	-0.3574	-0.3624
					.9522	0.0155	-0.1598	0.1533	-0.2581

y/s = 0.856				
x/c	Upper		Lower	
	Real	Imag	Real	Imag
.1955	0.0220	-0.0994	0.2048	0.0056
.2458	0.0010	-0.1005	0.2182	0.0526
.2915	-0.0104	-0.0895	0.2205	0.0917
.3454	-0.0018	-0.0705	0.2345	0.1789
.4519	0.0273	-0.0899	0.1206	0.3422
.5497	0.2157	0.1115	-0.1634	0.5150
.6025	0.1073	1.9064	-0.5421	0.7977
.6545	-0.8313	0.8169	-1.2556	0.8342
.7049	-1.0831	0.1696	-1.9732	0.6297
.7808	-1.1368	-0.0040		

(x-1) Tabulated data for test case 9E46 (point.90-D-59)
Figure 6. Continued.

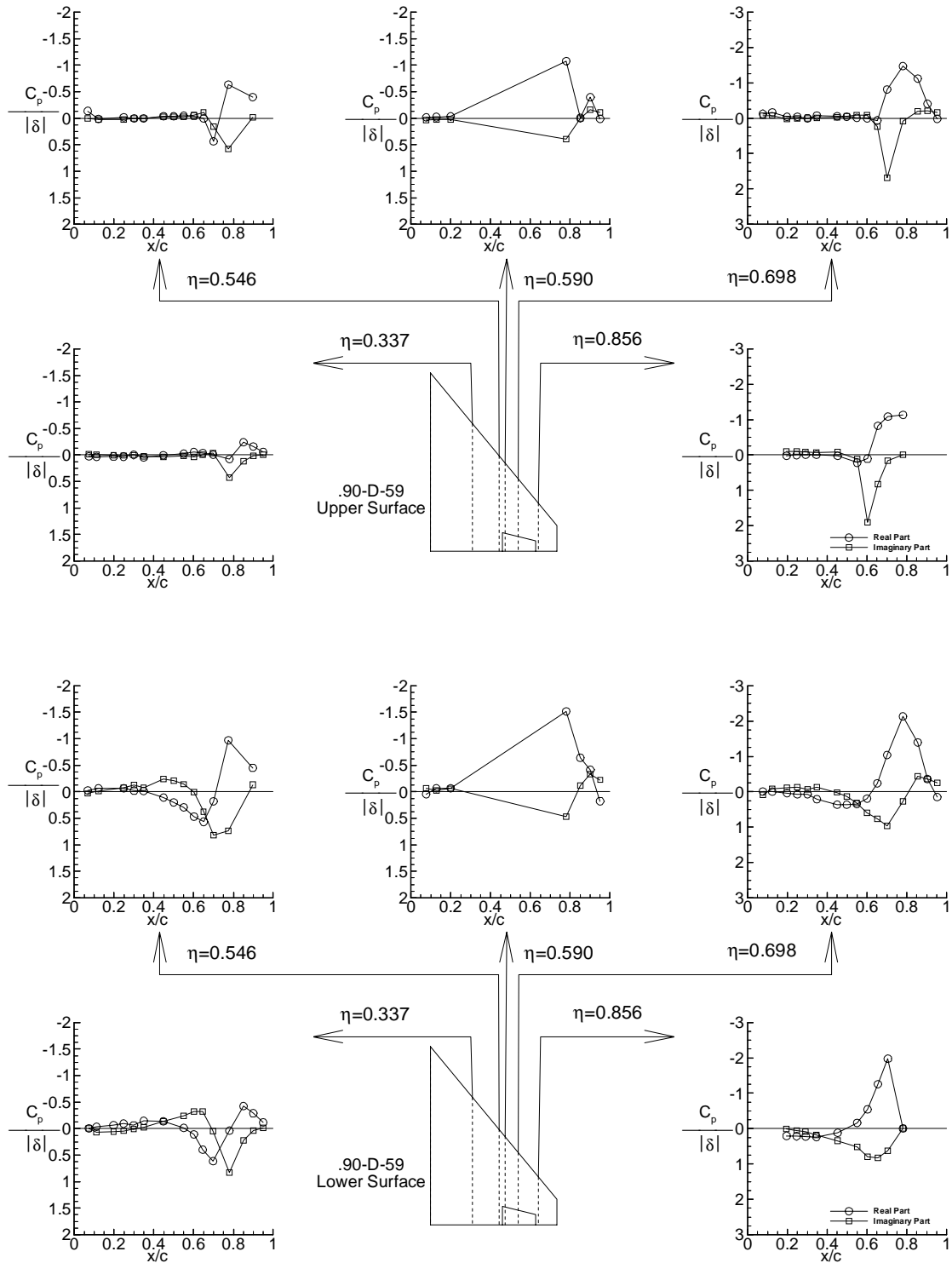

REPORT DOCUMENTATION PAGE			Form Approved OMB No. 0704-0188	
Public reporting burden for this collection of information is estimated to average 1 hour per response, including the time for reviewing instructions, searching existing data sources, gathering and maintaining the data needed, and completing and reviewing the collection of information. Send comments regarding this burden estimate or any other aspect of this collection of information, including suggestions for reducing this burden, to Washington Headquarters Services, Directorate for Information Operations and Reports, 1215 Jefferson Davis Highway, Suite 1204, Arlington, VA 22202-4302, and to the Office of Management and Budget, Paperwork Reduction Project (0704-0188), Washington, DC 20503.				
1. AGENCY USE ONLY (Leave blank)		2. REPORT DATE March 1999	3. REPORT TYPE AND DATES COVERED Technical Memorandum	
4. TITLE AND SUBTITLE Computational Test Cases for a Clipped Delta Wing With Pitching and Trailing-Edge Control Surface Oscillations			5. FUNDING NUMBERS WU 522-31-81-03	
6. AUTHOR(S) Robert M . Bennett and Charlotte E. Walker				
7. PERFORMING ORGANIZATION NAME(S) AND ADDRESS(ES) NASA Langley Research Center Hampton, VA 23681-2199			8. PERFORMING ORGANIZATION REPORT NUMBER L-17822	
9. SPONSORING/MONITORING AGENCY NAME(S) AND ADDRESS(ES) National Aeronautics and Space Administration Washington, DC 20546-0001			10. SPONSORING/MONITORING AGENCY REPORT NUMBER NASA/TM-1999-209104	
11. SUPPLEMENTARY NOTES Bennett: Langley Research Center, Hampton, VA Walker: Cooperative Engineering Education Student, University of Tennessee, Knoxville, TN				
12a. DISTRIBUTION/AVAILABILITY STATEMENT Unclassified-Unlimited Subject Category 02 Distribution: Standard Availability: NASA CASI (301) 621-0390			12b. DISTRIBUTION CODE	
13. ABSTRACT (Maximum 200 words) Computational test cases have been selected from the data set for a clipped delta wing with a six-percent-thick circular-arc airfoil section that was tested in the NASA Langley Transonic Dynamics Tunnel. The test cases include parametric variation of static angle of attack, pitching oscillation frequency, trailing-edge control surface oscillation frequency, and Mach numbers from subsonic to low supersonic values. Tables and plots of the measured pressures are presented for each case. This report provides an early release of test cases that have been proposed for a document that supplements the cases presented in AGARD Report 702.				
14. SUBJECT TERMS Unsteady aerodynamics; Transonic flow; Computational fluid dynamics			15. NUMBER OF PAGES 92	
			16. PRICE CODE A05	
17. SECURITY CLASSIFICATION OF REPORT Unclassified	18. SECURITY CLASSIFICATION OF THIS PAGE Unclassified	19. SECURITY CLASSIFICATION OF ABSTRACT Unclassified	20. LIMITATION OF ABSTRACT UL	